

Ana Güç Devresi

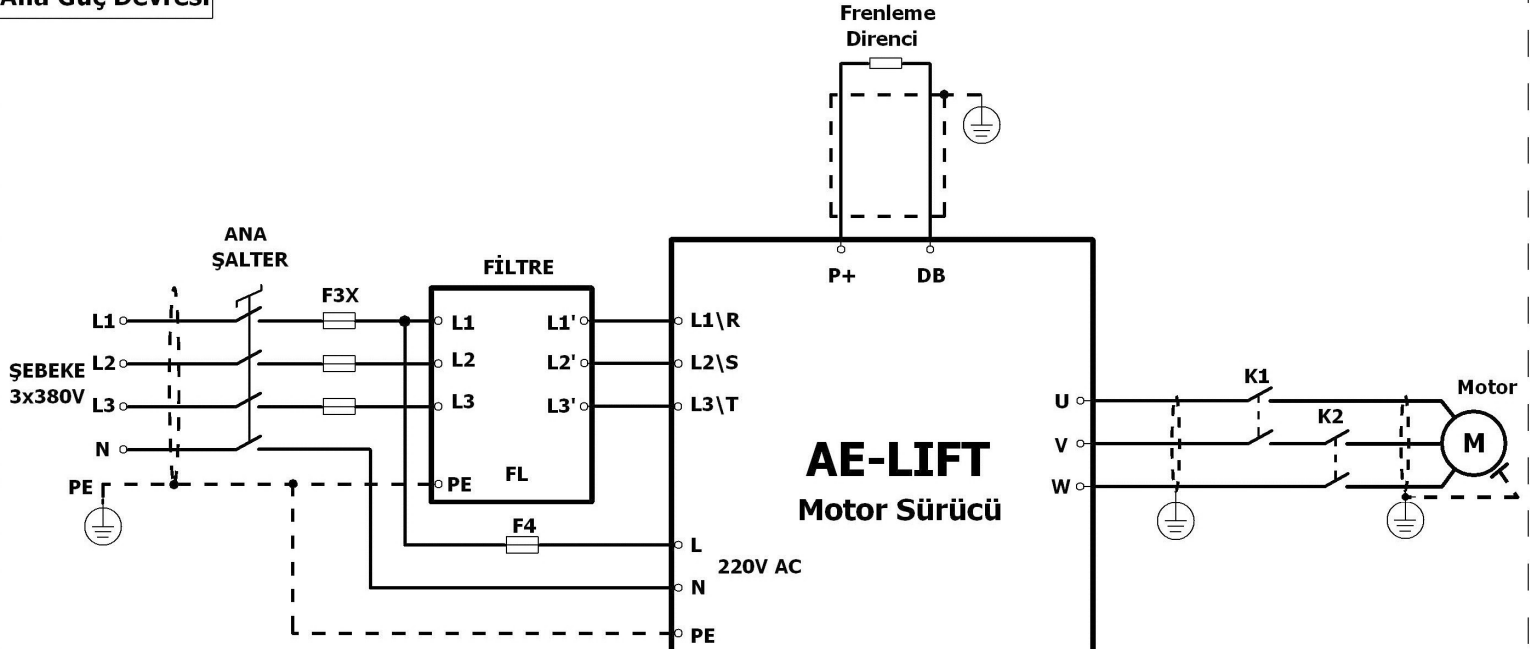

Kontrol Devresi

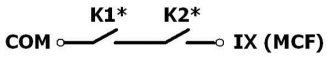
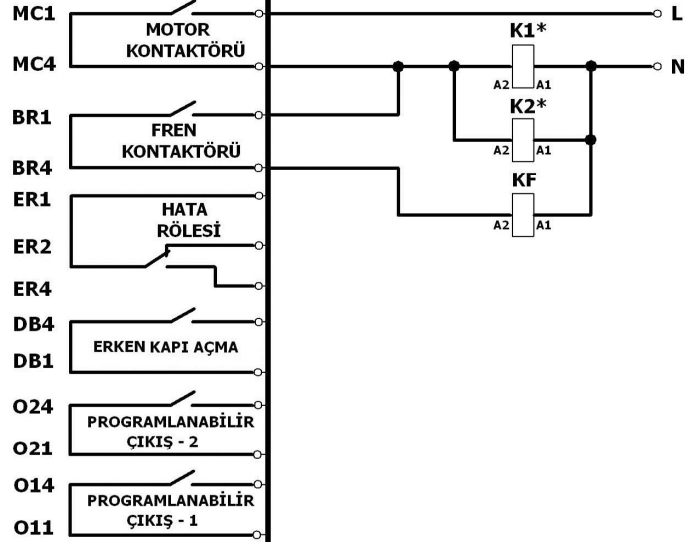
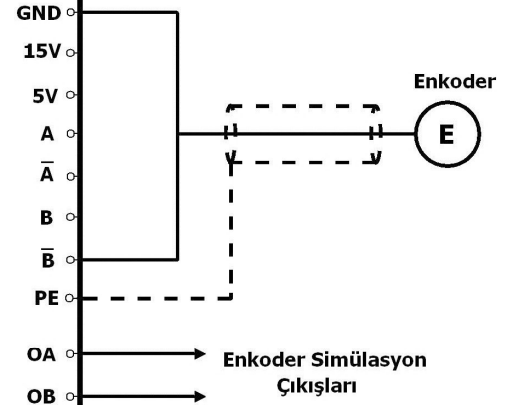
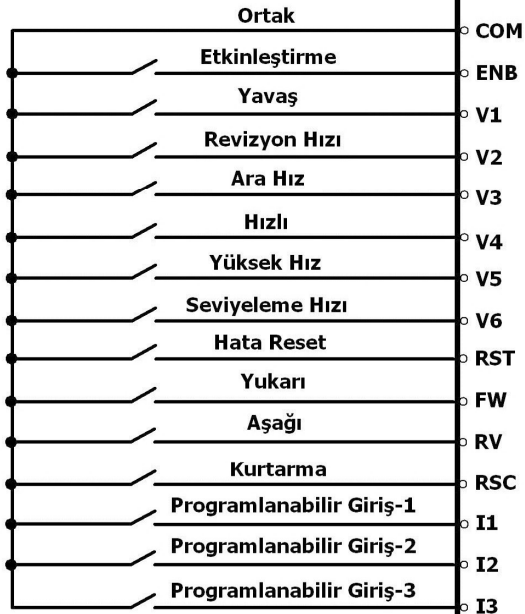

Motor kontaktörleri (K1*-K2*) AE-LIFT motor sürücü tarafından anahtarlığında, programlanabilir girişlerden herhangi birine (I1,I2,I3) kontaktör denetimi (MCF) özelliği tanımlanmalı ve yandaki bağlantı şekli uygulanmalıdır.