

R : 220V PHASE
MP : 220V NEUTRAL
R-S-T : 3 PHASE 3x380V
RA : DOOR OPEN CONTACTOR (220V AC)
RK : DOOR CLOSE CONTACTOR (220V AC)
RAY : AUXILIARY RELAY OF DOOR OPEN CONTACTOR (24V DC)
RKY : AUXILIARY RELAY OF DOOR CLOSE CONTACTOR (24V DC)
STR1 : TRANSFORMER INPUT CIRCUIT BREAKER
AL : DOOR OPEN LIMIT SWITCH
KL : DOOR CLOSE LIMITSWITCH

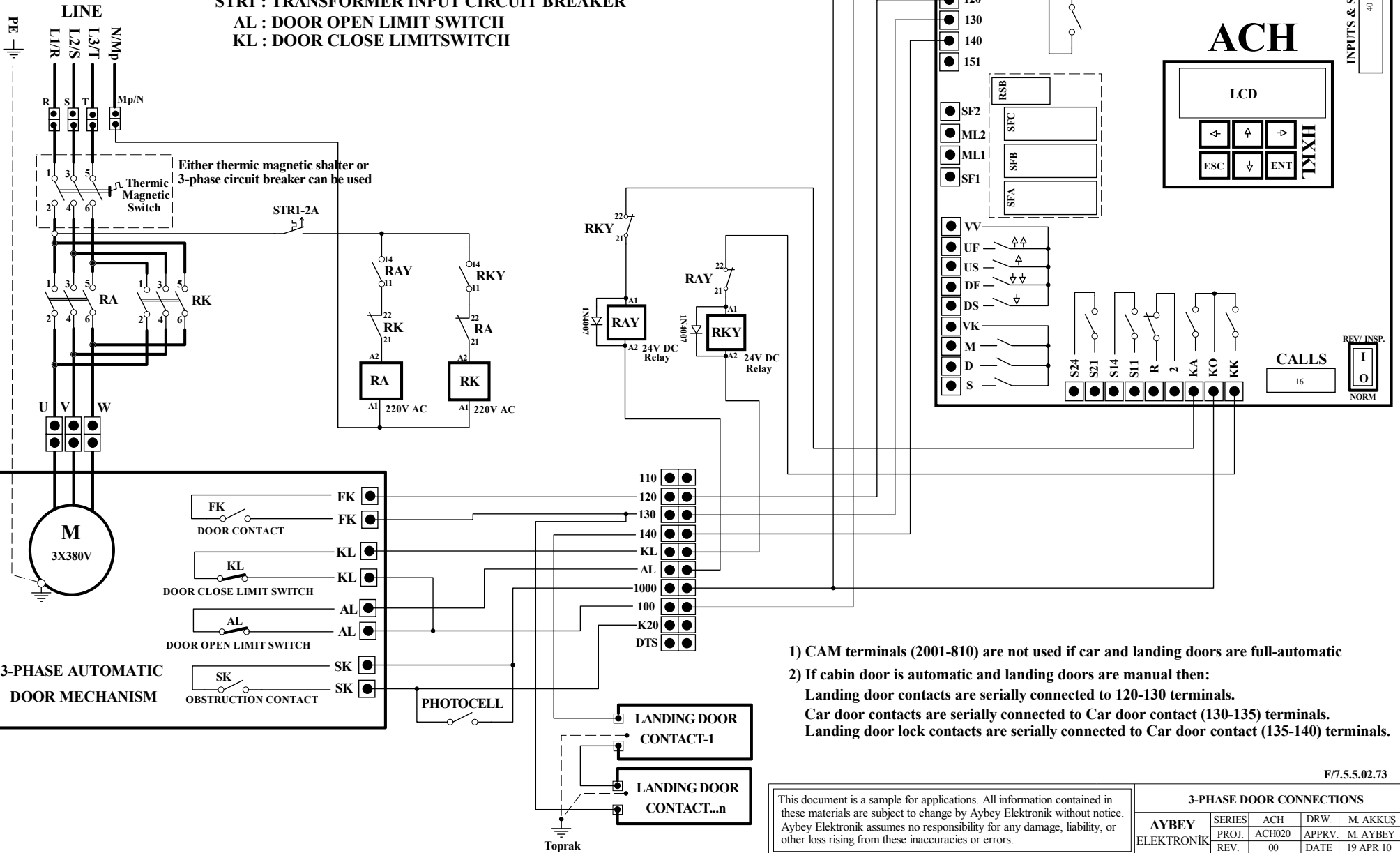

- 1) CAM terminals (2001-810) are not used if car and landing doors are full-automatic
- 2) If cabin door is automatic and landing doors are manual then:
 Landing door contacts are serially connected to 120-130 terminals.
 Car door contacts are serially connected to Car door contact (130-135) terminals.
 Landing door lock contacts are serially connected to Car door contact (135-140) terminals.

This document is a sample for applications. All information contained in these materials are subject to change by Aybey Elektronik without notice. Aybey Elektronik assumes no responsibility for any damage, liability, or other loss rising from these inaccuracies or errors.

F/7.5.5.02.73

3-PHASE DOOR CONNECTIONS				
AYBEY ELEKTRONİK	SERIES	ACH	DRW.	M. AKKUŞ
	PROJ.	ACH020	APPRV.	M. AYBEY
	REV.	00	DATE	19 APR 10