

AYBEY ELEKTRONİK

AC Series Lift Control System

USER MANUAL

AC SERIES LIFT CONTROL SYSTEM

USER MANUAL

VERSION: 1.15



©AYBEY ELEKTRONİK SAN. TİC. A.Ş.

Sanayi Mah. Hızır Reis Cad. No:26 34906 Pendik – İstanbul / Türkiye

Tel: (90) (216) 394 50 55 (pbx) Faks: (90) (216) 394 50 58

e-mail: destek@aybey.com

www.aybey.com

CONTENTS

- GENERAL DESCRIPTION 1**
- A) COMPONENTS AND CONFIGURATIONS 1
- B) PANEL VOLTAGE INFORMATION 2
- C) INPUTS AND OUTPUTS 2
- D) SHAFT INFORMATION COLLECTION 3
- E) SAFETY LINE STRUCTURE 3
- F) COMPUTER CONNECTION 4
- OUTPUT TERMINALS AND THE MEANINGS OF THE ABBREVIATIONS..... 5**
- CHAPTER 1: LCD SCREEN AND KEYPAD USAGE..... 7**
- 1-A) STARTUP SCREENS 7
- 1-B) MAIN SCREEN 8
- 1-C) MONITORING OF INPUTS 13
- 1-D) DEFINITION OF INPUTS 18
- 1-E) MAIN MENU 19
- 1-F) SETTING PARAMETERS 20
- 1-G) GIVING CALLS BY KEYPAD 23
- 1-H) SOFTWARE VERSION NUMBER 23
- CHAPTER 2: PARAMETERS 24**
- 2-A) P1-MAIN PARAMETERS 24
- 2-B) P2-AUXILIARY PARAMETERS 28
- 2-C) P3-TIMINGS 36
- 2-D) P4-FLOOR PARAMETERS 40
- 2-D-1) K1-SET DISPLAYS 40
- 2-D-2) K2-SET DOOR A and K3-SET DOOR B 41
- 2-D-3) K4-CABIN CALLS 42
- 2-D-4) K5-HALL CALLS 43
- 2-D-5) K6-ENCODER PULSE OF FLOORS 43
- 2-D-6) K7-GENERAL PULSE 44
- 2-D-7) K8-CALL REGISTER PERIODS 45
- 2-E) P5-MAINTENANCE TIME 45
- 2-F) P6-OUTPUT DEFINITIONS 46
- 2-G) P7-INPUT DEFINITIONS 49
- 2-H) P8-DATE & TIME 49
- 2-I) P9-UTILITIES 50
- 2-I-1) R1-DISPLAY UTILITIES 50
- 2-I-2) R2-FACTORY SETTINGS 50
- 2-I-3) R3-SET ALL INPUTS 50
- 2-I-4) R4-MODEM SETTINGS 51
- 2-I-5) R5-RESET PULSES 51
- 2-I-6) R6-OTHER UTILITIES (Do NOT Use) 51
- 2-I-7) R7-SET PASSWORD 51
- 2-I-8) R8-COUNTER 52
- 2-I-9) R9-ACCESS CONTROL 52
- 2-I-10) RA-ENCODER SETUP 55
- 2-I-11) RB-ENCODER DIRECTION (Absolute Encoder) 56
- 2-J) P0-MAX START 56
- 2-K) PA-LIFT NUMBER 56
- CHAPTER 3:ERROR LOG AND ERROR CODES 57**
- CHAPTER 4: VARIABLES AND LANGUAGE 61**

CHAPTER 5:UCM SERVICE	62
5-A) U1-CLEAR ERROR	62
5-B) U2-UCM TEST (SLB BOARD REQUIRED FOR ACT/ACS SERIES)	62
5-C) U3-TEST TIME	62
5-D) U4-TEST START	62
5-E) U5 -TEST COUNTER	62
5-F) U6 -VALVE TEST	62
5-G) UCM CONTROL OPERATION IN GEARED MACHINE SYSTEMS	63
5-G-1) OPERATION OF THE SYSTEM WHEN [B58]=1 (ON IN MOTION).....	63
5-G-2) OPERATION OF THE SYSTEM WHEN [B58]=2 (ALWAYS ON).....	64
5-G-3) OPERATION OF THE SYSTEM WHEN [B58]=3 (ALWAYS ON+SLEEP)	65
5-G-4) UCM DETECTION AND CONTROL.....	65
5-G-5) MANUEL UCM TEST PROCEDURES	65
5-H) UCM CONTROL OPERATION IN GEARLESS MACHINE SYSTEMS	67
5-H-1) UCM DETECTION AND CONTROL.....	67
5-H-2) MANUEL UCM TEST PROCEDURE	67
5-I) UCM CONTROL OPERATION IN HYDRAULIC LIFTS	69
5-I-1) AUTOMATIC (PERIODIC) TEST.....	69
5-I-2) AUTOMATIC TEST PROCEDURE DEPENDS ON COUNTER SYSTEM	69
5-I-3) UCM DETECTION AND CONTROL	70
OPTIONAL BOARDS	71
ACH OPTIONAL BOARDS	74
ACT OPTIONAL BOARDS	75
ACS OPTIONAL BOARDS	76
CONNECTION DIAGRAMS	77
CAR CONNECTION (PARALLEL COMMUNICATION)	77
CAR CONNECTION (SERIAL COMMUNICATION)	78
FLOOR CONNECTION (PARALLEL COMMUNICATION)	79
FLOOR CONNECTION (SERIAL COMMUNICATION)	80
INSPECTION BOX (PARALLEL COMMUNICATION)	81
INSPECTION BOX (SERIAL COMMUNICATION WITH SCC)	82
INSPECTION BOX (SERIAL COMMUNICATION WITH SCE/SCF)	83
GROUP LIFT (DUPLEX) CONNECTION (PARALLEL COMMUNICATION)	84
GROUP LIFT CONNECTION (SERIAL COMMUNICATION)	85
SAFETY CIRCUIT (AUTOMATIC DOOR)	86
SAFETY CIRCUIT (SWING DOOR)	87
FLOOR SELECTOR MAGNET MAP AND LIMIT SWITCHES LOCATION	88
MONO-STABLE COUNTER SYSTEM MAGNET MAP	89
ENCODER COUNTER WITH MONO-STABLE SHALTER MAGNET MAP	90
PRE-OPENING DOOR LIMIT SWITCHES LOCATION IN SHAFT ENCODER SYSTEM	91
OVERSPEED GOVERNOR CONNECTION	92
GEARLESS MACHINE CONNECTION	93
ACT BOARD I/O CONFIGURATION	94
PRE-OPENING DOOR FUNCTION WITH SLB DOOR BRIDGING BOARD AND INVERTER	95
COMPUTER CONNECTION	96
CE CERTIFICATES	97
ACH CONTROLLER BOARD CE CERTIFICATE	97
ACH CONTROL PANEL CE CERTIFICATE	98
ACT CONTROLLER BOARD CE CERTIFICATE	99
ACT CONTROL PANEL CE CERTIFICATE	100
ACS CONTROLLER BOARD CE CERTIFICATE	101
ACS CONTROL PANEL CE CERTIFICATE	102
SLB4 DOOR BRIDGING BOARD CE CERTIFICATE	103

PREFACE

AC Series Lift Control System has been designed to fulfill the needs of lift sector at new age. One of the main aims of this series is to integrate lift control system with today's advanced computer systems.

AC Series Lift Control System is controlled by a 32-bit high performance microcontroller. Besides having all features of general lift control systems, AC Series can also communicate with a computer directly or via internet. By this way it is possible to access and observe all lift motion and edit parameters for authorized users by a computer.

In this manual, you can find detailed information about using AC Series Lift Control System, technical documents and schematics. If you think that this manual is not enough or it is not compatible with hardware or software version of your system, you can download latest version of the manual from website of Aybey Elektronik (www.aybey.com) or send an e-mail to request.

We will continue to develop this product with your support and suggestions. Therefore, if you face any problem while using this product or if you have any suggestions to make it better, please inform us by e-mail (support@aybey.com).

Aybey Elektronik

GENERAL DESCRIPTION

A) COMPONENTS AND CONFIGURATIONS

Systems contain the following boards:

ACS : It is the main controller board of ACS system. It contains microcontroller, LCD display and keypad, to manage system. This system works in electric lifts, has 2 programmable inputs and 4 programmable relay outputs.

ACH : It is the main controller board of ACH system. It contains microcontroller, LCD display and keypad, to manage system. This system works in hydraulic lifts, has 2 programmable inputs and 3 programmable relay outputs.

ACT : It is the main controller board of ACT system. It contains microcontroller, LCD display and keypad, to manage system. This system works in electric lifts, has 2 programmable inputs and 2 programmable relay and 1 transistor outputs.

ACC : It is the car controller board that supports up to 64 floors. It gets cabin calls and signal inputs, collects information from switches and detectors placed on the car and transmits to main controller. It contains 3 (optionally 15) programmable relay outputs and 8 (optionally 16) programmable inputs.

SCC : It is the car controller board that supports up to 16 floors. It gets cabin calls and signal inputs, collects information from switches and detectors placed on the car and transmits to main controller. It contains 1 programmable relay outputs and 8 programmable inputs.

SCE : It is the car controller board that supports up to 16 floors. It gets cabin calls and signal inputs, collects information from switches and detectors placed on the car and transmits to main controller. It contains 1 programmable relay outputs and 8 programmable inputs, emergency lighting, battery charger and alarm system. It can use with AFM (Announce Board).

OUT : This board contains 4 programmable output relays.

INPS : This board contains 4 programmable inputs.

ENI : Encoder terminals connection board.

CSI : This is CAN interface board. One CSI is used to collect shaft information in ACH/ACT systems. If the controller works in a lift group then use second CSI board for group communication connection.

ETH : Ethernet interface board.

USB : USB interface board.

RS232 : RS232 interface board.

IDC : ERS connection interface board.

IO : It is the I/O board for the call registers which contains 8 I/Os. (ACH/ACT)

RTC : Real Time Clock board. (ACH and ACT Series)

ACSK : Serial communication terminal board.

ACPK : Parallel communication terminal board. (ACH and ACT Series)

ACB : Parallel Bus Support Board

ETU : Computer connection board for Ethernet and USB.

I. SERIAL CONFIGURATION

In this configuration, all inputs and outputs of shaft are transmitted serially through CAN-Bus network except safety circuit. (Add CSI board in ACH and ACT Series)

II. PARALLEL CONFIGURATION

ACH and ACT Series support this configuration. Controller communicates with car and landings in point to point connection. Add I/O board for command system and floor requirements and add CSI board in group lift.

III. SERIAL CAR – PARALLEL LANDINGS CONFIGURATION

ACH and ACT Series support this configuration with CSI board. Add I/O board depends on number of push-buttons in landings.

IV. ERS (EKS) OPTION

ESM/EGH (Gearless): Mainboard of Electronic Rescue System. It contains microcontroller circuit and has two serial communication interfaces for controller board of panel and motor inverter boards.

EPS: Power supply board of Electronic Rescue System. It also charges batteries in normal mode.

EMD: Motor driver board. It drives 3-phase lift motor in rescue mode.

APS : Battery charge board of ERS system. Use in systems with UPS + Battery.

B) PANEL VOLTAGE INFORMATION

- a. **Safety Circuit Voltage**: Depends on the contactor coil voltage. Maximum allowed voltage is 230V AC.
- b. **Signal Voltage**: 24V DC is used for signal lamps and control of relays on the boards. The current of this supply is mainly determined by the current requirements of the push-buttons used in the system.
- c. **Microcontroller Voltage**: 10V AC is required for the power supply of the microcontroller circuit.

C) INPUTS AND OUTPUTS

The power supply for signal and control circuits is 24V DC.

All inputs except safety circuit monitoring detect a signal as present if it connected to the reference (0V) of 24V circuit. They run active low and transmit data via an optocoupler. All inputs and outputs are 100% galvanically isolated from the microcontroller circuit.

The outputs are mainly made of relays. Some outputs are dedicated for a purpose where some of them are user programmable.

D) SHAFT INFORMATION COLLECTION

Shaft information can be collected in the following ways:

I. SHAFT INFORMATION WITH MAGNETIC SWITCHES:

The required magnet switches are shown in the following table:

	Deceleration Distance < ½ Floor to Floor Distance		Deceleration Distance > ½ Floor to Floor Distance		Program Input
	No Releveling	With Releveling	No Releveling	With Releveling	
Floor Counter	B	B			M0
Floor Counter Up		S	B	B/S	M1
Floor Counter Down		S	B	B/S	M0
Floor Level	B/S	B/S	B/S	B/S	MK
Floor Level Up		B/S		B/S	MKU
Floor Level Down		B/S		B/S	MKD
Releveling Allowed		B/S		B/S	ML1/ML2
Door Zone	*	SLB Board	*	SLB Board	**

B: Bistable Magnet Switch

S : NO Magnet Switch

* In case of pre-opening of doors, the case ** must be applied.

** For releveling with open doors, an external SLB board must be connected to ACS/ACT Series, which bridges door contacts during releveling. Connect A0 terminal to ML1 and B0 terminal to ML2 of SLB board which is closed at door zone and open elsewhere.

II. SHAFT INFORMATION WITH ABSOLUTE ENCODER

An absolute encoder can be used to collect shaft information. In case of a power cut, no zeroing operation is needed. No other switch is necessary for shaft and releveling information.

In case of releveling with open doors or pre-opening doors, the door zone detector and SLB board (ACS/ACT Series) must be used exactly as explained above.

III. SHAFT INFORMATION WITH INCREMENTAL ENCODER

An incremental encoder can be used to collect shaft information. Pulse A and Pulse B outputs of the encoder are connected to ENI board terminals. In case of releveling with open doors or pre-opening doors, the door zone detector and SLB board (ACS/ACT Series) must be used exactly as explained above.

E) SAFETY LINE STRUCTURE

The safety line is convenient for any safety line voltage (24V AC...230V AC and 24V DC...110V DC). The power supply of the safety circuit is labeled as 110. The current flows through STOP circuit which returns to the terminal 120. The door contacts are connected between the terminals 120-130. Finally, the door locks are connected between the terminals 130-140.

Here is the explanation of terminals:

120 : It stands for stop circuit. If terminal 120 is present then it means that pit switch, shaft final switches, speed regulator, parachute and car top switch are all closed.

130 : When this terminal is present then it means the cabin door is closed.

140 : When this terminal is present, then it means that the landing doors are closed (for full automatic systems) or the door locks are closed (for wing doors). 140 is also power supply terminal for contactor coils or hydraulic valves.

a) Contactor Coil Voltage and Safety Line Voltage

Safety line voltage is allowed between the limits 24V AC...230V AC and 24V DC...110V DC. The contactors and valves which drive directly motor, inverter and hydraulic units must have the same coil voltages as the safety line voltage. If any of these components has different coil voltages than the safety line, one or more SFX boards must be connected to the circuit. You will find related connection methods in schematics.

b) System with Door Bridging (Pre-Opening Doors or Releveling with Open Doors)

When releveling with open doors or pre-opening doors are desired then SLB board must be added to ACS/ACT Series. This special SLB board/circuit bridges 120 - 140 through its terminals SF1 and SF2. In ACH Series, door bridging is standard.

If any relay fails for any reason then the circuit blocks itself and never bridges the SF1 and SF2 terminals again which bridges the door contacts. According to the standard EN-81, this bridging circuit has to be driven by two independent door zone detectors.

F) COMPUTER CONNECTION

AC series controller systems support computer connection through USB or Ethernet (LAN or Internet). LiftNet computer interface program supports all things as you can do from controller panel:

- Observe lift motions and register calls
- Check error list
- Parameter settings
- Check inputs – outputs and timers
- Parameter Save / Load / Transfer

You can download interface program and drivers form <http://www.aybey.com/eng/programlar.htm>. Check “LiftNet Installation Manual” for detailed information.

OUTPUT TERMINALS AND THE MEANINGS OF THE ABBREVIATIONS			
100	Signal Circuit Supply (+24V DC)	1	Phase Line output for Cabin (220V AC)
1000	Signal Circuit Ground	1F – NF	Well and Cabin Lamp Line – Neutral
10AC	10V AC Voltage	2	Phase Line Output for Cabin Lamp (220V)
L1, L2, L3	Main Phases	A...G	Right Display Segment Outputs
MP / N	Neutral	2A...2G	Left Display Segment Outputs
110	Safety Circuit Supply	M	Hydraulic Lift Motor Contactor
111	Pit Stop Button	D	Hydraulic Lift Delta Contactor
112	Overspeed Governor	S	Hydraulic Lift Star Contactor
113	Up – Down Well Limits Supply	CLS	Close Door Signal (Automatic Door)
114	Up – Down Well Limits Return	OPN	Open Door Signal (Automatic Door)
115	Parachute Contact	DCM	Door Signal Common
116	Car Top Stop Button	CH0	Serial Communication Line for Well
117	Emerg. Elec. Op. Switch Stop Circuit Return	CL0	Serial Communication Line for Well CL
120	Stop Circuit Return	CH1	Serial Communication Line for Group
130	Door Contacts Return	CL1	Serial Communication Line for Group
140	Door Locks Return	LCM	Common of Automatic Door Limit
150-151	Safety Circuit Common	AL	Automatic Door Open Limit
840	Positive Terminal of Brake	KL	Automatic Door Close Limit
2000	Negative Terminal of Brake	S1...S4	Programmable Relays
2001	Positive Terminal of CAM	O1...OC	Programmable Relay Outputs
810	Negative Terminal of CAM	12	Busy Signal
817	Lower Limit (End of fast speed way)	31	Down Arrow Signal
818	Upper Limit (End of fast speed way)	32	Up Arrow Signal
FXX	Fuses	35	Overload Signal
FFP	Brake and Cam Fuse	39	Out Of Service (Inspection) Signal
FK	Contactor Fuse (220V AC)	C0...C32	Register Button Inputs/Register Lamp
FKL	Cabin Lamp Fuse	ML1, ML2	Door Open Zone Limit Signal for SLB
FWCX	Safety Line and Contactor Supply Fuse	COM (VCM)	Valve Common
U1, V1, W1	Motor High Speed Inputs	G0...G5	Gray Code Outputs
U2, V2, W1	Motor Low Speed Inputs	M0...M4	Gray Code Inputs
FKI	Motor/Phase Protection Relay	ALF	Alarm Filter Output for Emergency
FAN	Supply Voltage for Motor Fan	THR	Temperature Control Input for Machine
I0...I12	Programmable Inputs	KF	Brake Contactor
T1-T2	PTC Motor Thermistor Terminals	FR	Brake Contactor Auxiliary Relay
TMS	Thermal Magnetic Circuit Breaker	FD-/FD+	Floor Level Detector Output Display
TR	Thermal Relay	KS	Hydraulic (Re)leveling Contactor
190	Hall Call Common for Simple Push Button	EV-/EV+	Emergency Down Valve Supply
HU	Upper Limit (End of High speed way)	KM	ERS(EKS) Motor Output Contactor
HD	Lower Limit (End of High speed way)	MC	Line Input Contactor of Panel with
870	Emergency Electrical Operation Switch	EMA	ERS Motor Current
550	Emergency Electrical Operation Down Switch	RK-RA	Tri-phase Door Contactors
551	Emergency Electrical Operation Up Switch	LDB	Load Button
869	Inspection Switch	DIK	Door Inspection Key
500	Inspection Down Button	DER	Device Error Input
501	Inspection Up Button	RUN	RUN Input
555	Fast Inspection Input	DPM	Earthquake Input
802	Minimum Load	FRM	Fireman Switch
804	Overload	UF	Up Fast Valve
805	Full Load	US	Up Slow Valve
DTS	Open Door 1 Button	DF	Down Fast Valve
K20	Close Door 1 Button	DS	Down Slow Valve
DT2	Open Door 2 Button	K1-K2	Inverter (VVVF) Output Contactors
K22	Close Door 2 Button	MCR	Inverter (VVVF) Output Contactor
FOT	Door 1 Photocell	RAY	2 nd Door Open Relays
FT2	Door 2 Photocell	RKY	2 nd Door Close Relay
FR1	Fire Signal 1 Input	TRF	Low Voltage Transformer inside Panel
FR2	Fire Signal 2 Input	PK	Line Control Contactor for Hydraulic
DL1	Door 1 Open Input	KUPS	UPS Output Contactor
DL2	Door 2 Open Input	FKR	UPS Phase Protection Contactor

OUTPUT TERMINALS AND THE MEANINGS OF THE ABBREVIATIONS			
DOA	Door 1 Activate Input	BS	Gearless Machine Brake Release Shalter
DOB	Door 2 Activate Input	B1B, B2B	Gearless Machine Brake Release
LUP/NUP	UPS Phase/Neutral Inputs	LP/NP	UPS Phase/Neutral Outputs
917	Bottom Floor Level Limit	918	Top Floor Level Limit
EKF1, EKF2	Synchronous Machine Manual Brake	OR	Overspeed Governor Remote Control
SG1,SG2	Overspeed Governor A3 Coil Terminals	ORR+, ORR-	Overspeed Governor Reset Coil
KSG	OSG A3 Coil Driving Contactor	ORT+, ORT-	Overspeed Governor Test Coil
SGO	OSG A3 Coil Monitoring Contact	BR1, BR2	Synchronous Machine Brake Control
SGC	KSG Contactor Monitoring Contact	KSF1, KSF2	Safety Contactors
DLV	GMV Hydraulic Unit Additional A3 Valve	RDY	External Device Ready Signal Input
DSV	Bucher Hydraulic Unit Additional A3 Valve	B0...B5	Binary Code Output Terminals
HDU	OMAR Hydraulic Unit Additional A3 Valve	FTKR	Earth Leakage Relay
L10	Blain Additional A3 Valve	SS	Soft Starter Unit
MRS-A3	Switch for Manually Activating Overspeed	FUTKR	Earth Leakage Relay of UPS Output
MKU	Counter and Stopper in Up Direction	MKD	Counter and Stopper in Down Direction

CHAPTER 1: LCD SCREEN AND KEYPAD USAGE

ACS Series has an LCD screen with 4-rows 20-characters per line and 6-keys keypad. ACH/ACT Series have an LCD with 2 rows and 16 characters per line 6-key keypad.

Keys are located as below:

←	↑	→
ESC	↓	ENT

Functions of the keys differ in different menus. But generally, ESC is used to exit current menu; ENT is used to enter a menu or confirm any input; up and down arrows are used to move in menu lists and change value of a variant; left and right arrows are used to move left and right while changing the value of variant.

1-A) STARTUP SCREENS

When system is first energized or restarted, below screen displays.

ACS Series

```

AYBEY ELEKTRONiK
ACS x-yyy
system is loading..
                                OK
  
```

ACH and ACT Series

```

AYBEY ACHx-yyy
reading errors..
  
```

At this moment, system parameters are loaded and below screen is displayed.

ACS Series

```

ACS starting...

DD/MM/YYYY  HH:MM
  
```

ACH and ACT Series

```

ACH starting...
DD/MM/YYYY HH:MM
  
```

Meanings of the items in these screens are explained below.

x-yyy	Software Version
DD/MM/YYYY	Day/Month/Year DATE
HH:MM	Hour: Minute TIME

After displaying this screen about 3 seconds, "MAIN SCREEN" is displayed.

1-B) MAIN SCREEN

i) NORMAL MODE

a) ACS Series

```
[SDL] [→←]      16:37
.....
[ 01=] [INS] STOP  M+1
```

The main screen displays the most important lift parameters briefly at one look.

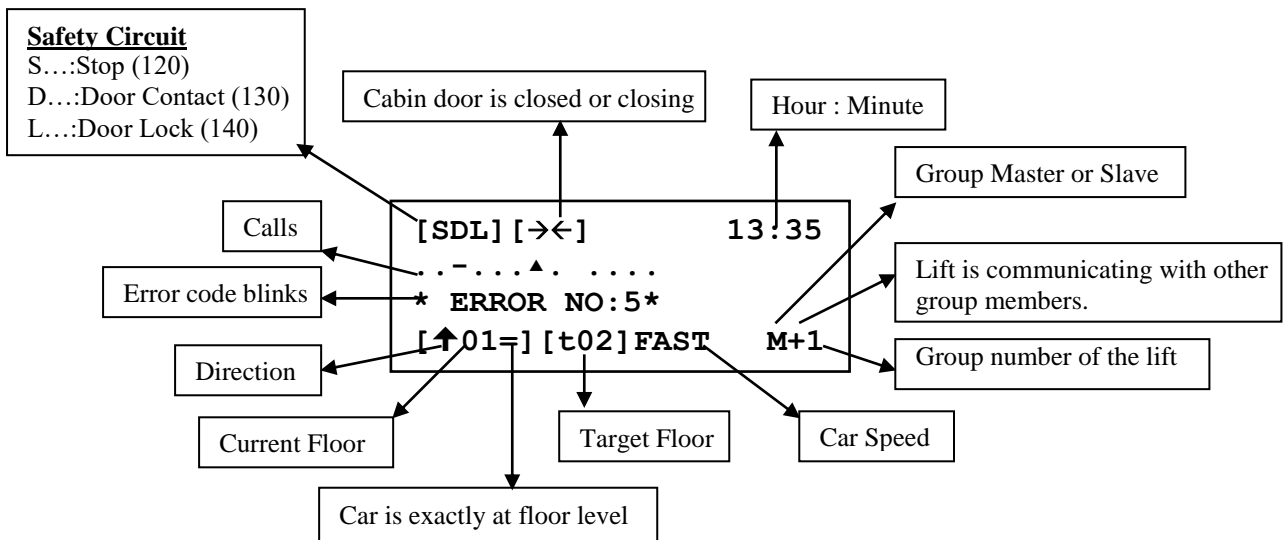

TOP ROW:

[S] : Stop circuit is closed.

[SD] : Stop and Door Contact circuits are closed.

[SDL] : Stop, Door Contact and Door Lock circuits are closed.

[↔] : Door is opening. (CAM is active)

[→←] : Door is closing. (CAM is inactive)

13:35 : HOUR:MINUTE

MID-ROWS (2,3):

Row 2 and 3 shows Call Registers. Most left character of row 2 shows the calls for bottom floor. As moving right, floor number increases. One character is used for each floor. The meanings of symbols are explained below:

- : No call for this floor
- : Cabin call for this floor
- ▲ : Up call for this floor
- ▼ : Down call for this floor

In a floor 1, 2 or 3 of these symbols can appear together at the same character (except •). In these rows, only defined floor number of characters can be seen.

BOTTOM ROW:

Columns [2, 3, 4, 5] : This group shows information about floor and moving direction of car.

- [05=] : Car is exactly at floor 5. (Car is exactly at floor level)
- [05] : Car is at floor 5. (Car is between floors)
- [↑05] : Lift has a target on up direction.
- [↓05] : Lift has a target on down direction.

Columns [8, 9, 10] : This group shows information about target and run mode of lift.

- [INS] : Lift is in INSPECTION mode.
- [t__] : Lift has no target.
- [t03] : Lift has a target of Floor 3.

Columns 12, 13, 14, 15, 16 : This group shows information about motion and speed of car.

- STOP** : Car is stopping.
- START** : Car is stopping but about to move. Lift is preparing conditions for moving. (Closing door)
- SLOW** : Car is moving at slow speed.
- FAST** : Car is moving at fast speed.
- HIGH** : Car is moving at high speed. (over 1m/s)
- MAINT** : Maintenance

Columns 18, 19, 20 : This group shows information about group operations. (Displays only in group lifts)

- M+1** : Group manager, group number is 1 and in communication with the other members.
- M-1** : Group manager, group number is 1 and cannot communicate with the other members.
- S+2** : Group member, group number is 2 and in communication with the other members.
- S-2** : Group member, group number is 2 and cannot communicate with the other members.
- I-3** : Group number is 3. It has no group job (Idle) because cannot communicate with any group member.

b) ACH and ACT Series

L↑00=INS→←FAST .
.....

The main screen shows the most important lift parameters briefly at one look.

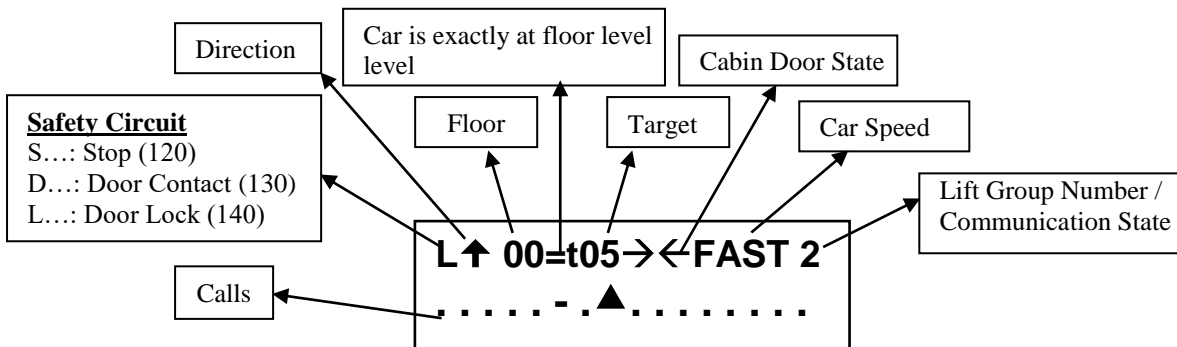

TOP ROW:

1st character shows safety circuit state

- : Whole Safety Line is open.
- S : Stop circuit is closed.
- D : Stop and Door Contact circuits are closed.
- L : Stop, Door Contact and Door Lock circuits are closed.

2nd character shows target direction

- ↑ : Target is UP direction.
- ↓ : Target is DOWN direction.

3, 4 and 5th characters show current floor and floor level

- 05= : Car is exactly at floor 5. (Car is exactly at floor level)
- 05 : Car is at floor 5. (Car is between floors)

6, 7 and 8th characters show target floor or Inspection

- INS : Lift is in INSPECTION mode.
- t : Lift has no target.
- t03 : Lift has a target of Floor 3.

9 and 10th characters show the state of cabin door and CAM

- ↔ : Door is opening (CAM is active)
- ← : Door is closing (CAM is inactive)

11, 12, 13, 14 and 15th characters show speed and state of cabin

- STOP : Car is stopping
- START : Car is stopping but about to move. Lift is preparing conditions for moving (Closing door)
- SLOW : Car is moving at slow speed
- FAST : Car is moving at fast speed
- HIGH : Car is moving at high speed (over 1m/s)
- MAINT : Maintenance

16th character shows information about group operations. (Displays only in group lifts)

- . : Simplex operation
- 1 - : Group manager, group number is 1 and cannot communicate with the other member
- 1 + : Group manager, group number is 1 and in communication with the other member
- 2 - : Group member, group number is 2 and cannot communicate with the manager
- 2 + : Group member, group number is 2 and in communication with the manager

BOTTOM ROW

This row shows Call Registers. Most left character shows the calls for bottom floor. As moving right, floor number increases. One character is used for each floor. The meanings of symbols are explained below:

- : No Call for this floor
- : Cabin Call for this floor
- ▲ : Up Call for this floor
- ▼ : Down Call for this floor

In a floor 1, 2 or 3 of these symbols can appear together at the same character (except ●)

In these rows, only defined floor number of characters can be seen.

ii) ERS (EKS) MODE

a) ACS Series

```
[SDL] [→←] 16:37
07.RESCUE UP
[↑01 ] [ERS] FAST
```

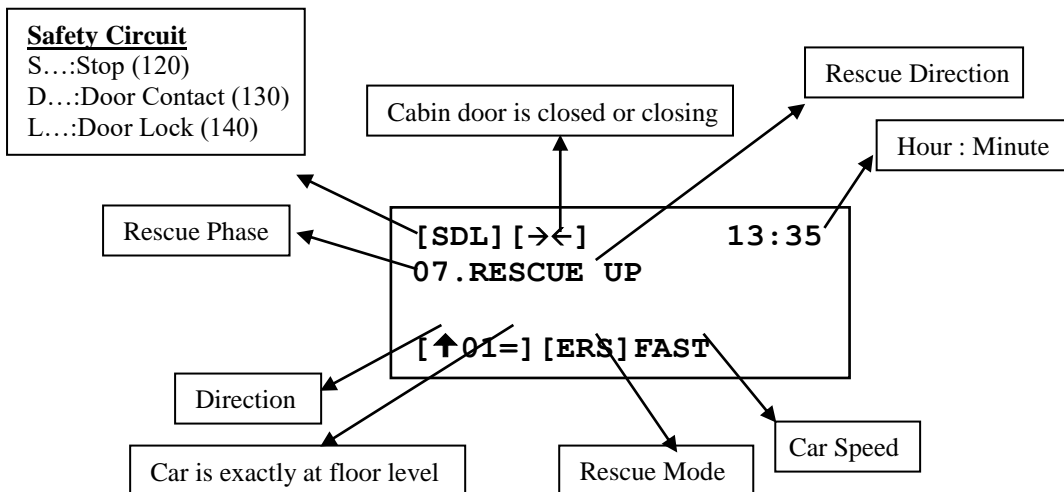

TOP ROW:

[S] : Stop circuit is closed.

[SD] : Stop and Door Contact circuits are closed.

[SDL] : Stop, Door Contact and Door Lock circuits are closed.

[↔] : Door is opening. (CAM is active.)

[→←] : Door is closing. (CAM is inactive.)

13:35 : Hour:Minute

ROW 2:

Second row shows rescue phase, situation and errors.

ROW 4:

Columns [2, 3, 4, 5] : This group shows information about floor and moving direction of car.

[01=] : Car is exactly at floor 1. (Car is exactly at floor level)

[01] : Car is at floor 1. (Car is between floors)

[↑01] : Lift has a target on up direction.

[↓01] : Lift has a target on down direction.

Columns [8, 9, 10] : This group shows information about target and run mode of lift.

[ERS] : Lift is in Rescue mode.

Columns 12, 13, 14, 15, 16 : This group shows information about motion and speed of car.

STOP : Car is stopping.

START : Car is stopping and preparing conditions for moving. (Closing door)

FAST : Car is moving at fast speed.

b) ACH and ACT Series

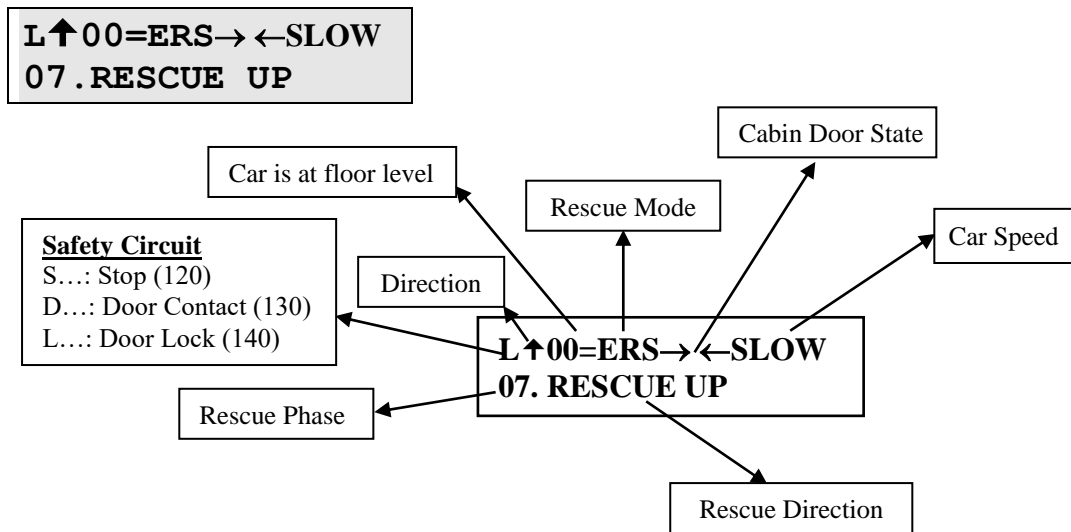

TOP ROW:

1st character shows safety circuit state

- : Whole Safety Line is open
- S : Stop circuit is closed
- D : Stop and Door Contact circuits are closed
- L : Stop, Door Contact and Door Lock circuits are closed

2nd character shows target direction

- ↑ : Target is UP direction
- ↓ : Target is DOWN direction

3, 4 and 5th characters show current floor and floor level

- 05= : Car is exactly at floor 5. (Car is exactly at floor level)
- 05 : Car is at floor 5. (Car is between floors)

6, 7 and 8th characters show target floor or Inspection

- ERS : Lift is in RESCUE mode.

9 and 10th characters show the state of cabin door and CAM

- ↔ : Door is opening (CAM is active)
- ← : Door is closing (CAM is inactive)

11, 12, 13, 14 and 15th characters show speed and state of cabin

- STOP : Car is stopping
- START : Car is stopping and preparing conditions for moving. (Closing door)
- FAST : Car is moving at fast speed

BOTTOM ROW

1, 2 and 3rd characters show the rescue phase

- 07. : Rescue Phase 7

4th and 16th characters show the state of rescue operation.

- RESCUE UP : The car is moving moving in rescue mode

1-C) MONITORING OF INPUTS

i) GENERAL SCREENS

On the main screen only important variables are shown. When you press (←) button when the screen is main screen then you will see the following screen:

ACS Series

120*	130*	140	FKK*
817*	818*	PTC*	CNT*
MK_	MKU	ML1	ML2
M0	M1	K20	DTS

ACH and ACT Series

120*	130*	140	FKK*
817*	818*	PTC*	CNT*

Pressing (←) button when you see the main screen is the shortcut for the section (M1-VARIABLES → N4-INPUTS). This section monitors all inputs. You can see number of codes with three characters with a '*' just after some of them. These codes represent an input and are listed below in a table. The inputs which have a '*' on the right side are active at the moment where the others are not active. For example on the screen we see that 120 and 130 are closed where 140 (door locks) are open. To switch to the second screen you can use (↑) button. Second input screen is shown below.

ACS Series

869	500	501	804
870	550	551	805
FOT	FR1	802	DER
THR	LDB	WTM	DIK

ACH and ACT Series

MK_	MKU	ML1	ML2
M0_	M1_	K20	DTS

To return back to the previous screen (↓) button is available.

Besides these two input screens you can switch more screens in these sections. Next coming screens show inputs with their programmed terminal number together. Shortly you can switch with (↓) and (↑) buttons between available input screens in this section.

Only 13 inputs are constant in the system. You cannot redefine or change the terminal of the following inputs: 120, 130, 140, 870, 817, 818, CNT, T1-T2, MK/MKD, MKU, ML1-ML2, 550 and 551. All other inputs must be programmed by the user according to the needs of the system. Any required input can be selected from the available inputs in the list below and can be connected to the terminal. The following list gives the input codes and their explanations.

INPUT NO	INPUT CODE	EXPLANATION	DEFINITION
	120	Stop Circuit	STANDARD
	130	Door Contact Circuit	STANDARD
	140	Door Lock Circuit	STANDARD
	870	Inspection switch in the lift controller	STANDARD
	817	High Speed Limit Downwards	STANDARD
	818	High Speed Limit Upwards	STANDARD
	CNT	Contact failure detection	STANDARD
	MK/MKD	Stopper and door zone limiter	STANDARD
	MKU	Stopper in up direction when two stoppers are selected in A10. M2-PARAMETERS → P1-MAIN.PRM.s. → A10-TWO STOPPERS must be 1.	STANDARD
	550	Inspection Down Button	STANDARD
	551	Inspection Up Button	STANDARD
	T1,T2	Thermistor Inputs	STANDARD
	ML1,ML2	Shalter which determines the leveling zone	STANDARD
1	M0_	1) Counter in one shalter system ([A05]=0) 2) Counter in down direction in two shalter system ([A05]=1)	USER
2	M1_	Counter in up direction in two shalter system ([A05]=1)	USER
3	869	Car top inspection switch	USER
4	K20	Door 1 Open Button	USER
5	DTS	Door 1 Close Button	USER
6	FOT	Photocell 1	USER
7	804	Overload contact	STD/USER
8	FR1	Fire 1 detector When a signal is present at this input then the system switches to the fire mode and moves to the fire floor stored in the parameter: M2-PARAMETERS → P2-AUX. PRM.s. → [B05] FIRE FLOOR	USER
9	805	Full Load Contact	USER
10	WTM	Waitman Switch	USER
11	FR2	Fire 2 detector When a signal is present at this input then the system switches to the fire mode and moves to the fire floor stored in the parameter: M2-PARAMETERS → P2-AUX. PRM.s. → [B40] FIRE FLOOR 2	USER
12	500	Inspection Down Button	STD/USER
13	501	Inspection Up Button	STD/USER
14	RUN	Run feedback RUN can be used as a feedback from the motor driver. The system waits for a delay defined in (M2-PARAMETERS → P3-TIMINGS → [C21]-WAIT FOR MOTION) just after sending move command. If no signal at terminal, which defined as RUN until the end of this time limit then an error with the number 38 is generated and system is stopped. If [C21] is 0 then no error is generated.	USER
15	DL1	Door 1 open limit input. It means door 1 is completely open.	USER
16	DL2	Door 2 open limit input. It means door 2 is completely open.	USER
17	K22	Door 2 Open Button	USER
18	DT2	Door 2 Close Button	USER
19	FT2	Photocell 2	USER
20	DOB	When M2-MAIN PRM.s → P2-AUX.PRM.s → [B18]-TWO DOORS SELECTION is 1, which is "TERMINAL INPUT" then this input functions as the control input for door B. In this case, if DOB has a signal then door B will be opened after a door open command.	USER

INPUT NO	INPUT CODE	EXPLANATION	DEFINITION
21	DOA	When two doors are present and M2-MAIN PRMs→P2-AUX.PRM→[B18]-TWO DOORS SELECTION is 1, which is "TERMINAL INPUT" then this input functions as the control input for door B. In this case, if DOA has a signal then door A will be opened after a door open command.	USER
22 23	SIF SIS	These inputs are not used in lift application. SIS and SIF are designed to be used as control inputs for lift simulator operation. Contact technical support department to run the lift in simulator mode without connected to a lift.	USER
24	DER	Driver Device Failure When the lift motor is managed by an external device, then the fault contact of this external device can be fed to the DER input. If used any motion is stopped when there is an active signal in DER input.	USER
25	FDT	This input terminal is used in variable speed applications in order to detect the speed when it is below a certain level.	USER
26	HD	High speed limit down	USER
27	HU	High speed limit up	USER
28	EMA	This input is for detecting the current level of speed regulator device for emergency rescue operation. This information is used in determining the direction of rescue operation. Any signal in this input during the direction test period of the emergency rescue operation means that the current level is above the set value in the tested direction so the opposite direction should be selected for easier rescue operation.	USER
29	LDB	This input is used to hold automatic door open for long times during loading and it is independent from photocell and door-open push-button. Holding time is set by parameter [C31]:LOADING PERIOD.	USER
30	802	Minimum Load Contact	USER
31	FRM	Fireman switch	USER
32	EKS	If this input is active and FKK input is passive at startup, system starts in Rescue mode.	USER
33...35	M2...M4	Floor Selector Gray Code Inputs. Active when [A05]=4 (GRAY CODE)	USER
36	DIK	Door Inspection Key Input which detects automatic landing door is opened manually by a key. When this normally closed input is opened, system passes to inspection mode automatically.	USER
37	THR	Machine Room temperature control input. Normally closed. When the temperature is between defined limit this input must be activated by an external temperature measuring device.	USER
38	FKI	External Phase Control Input	USER
39	DPM	Earthquake Alarm Input	USER
40	555	Fast Inspection Motion	USER
41	FRC	Fireman Car Key Input	USER
42	AGS	GSM Reporting Alarm Input	USER
43	RDY	System is Ready Input (For NGV A3)	USER
44	CAL	Calls in System Input	USER
45	UCM	UCM Device Error Input	USER
46	MKU	MKU Input	USER
47	VP1	When a signal is present at this input then the system moves to the VIP-1 floor stored in the parameter: M2-PARAMETERS→P2-AUX. PRMs.→ [B55] VIP1 FLOOR	USER

INPUT NO	INPUT CODE	EXPLANATION	DEFINITION
48	VP2	When a signal is present at this input then the system moves to the VIP-2 floor stored in the parameter: M2-PARAMETERS → P2-AUX. PRMs. → [B56] VIP2 FLOOR	USER
49	VP3	When a signal is present at this input then the system moves to the VIP-3 floor stored in the parameter: M2-PARAMETERS → P2-AUX. PRMs. → [B57] VIP3 FLOOR	USER
50	BR1	Brake Contact 1	USER
51	BR2	Brake Contact 2	USER
52	SGC	Overspeed Governor Contact (Normally Closed)	USER
53	SGO	Overspeed Governor Contact (Normally Open)	USER
54	WM2	Waitman 2 Key Input. Hall calls must be registered by Waitman in cabin. (Only in parallel system).	USER
55	DSB	Out of service (Relevelling is still functional)	USER
56	917	Bottom Level Limit (When [A05] = 3 or 4 and [A18] = 1)	USER
57	918	Top Level Limit (When [A05] = 3 or 4 and [A18] = 1)	USER
58	BAT	ERS system battery voltage level is OK	USER
59	K2C	The button for opening the door(NK) is normally closed switch(do not work at the same time with K20.)	USER
60	ERU	For rescue mod, easy way information coming from an inverter. If it is ‘0’ it is going up, if it is ‘1’ it is going down.	USER

i) INPUT TERMINAL SCREEN

Due to its flexible structure, the input terminals of AC Series control system are distributed to a number of boards. The places of these terminals are listed below.

INPUT NO	PLACE / SOCKET	BOARD NAME	TERMINAL NAME
I0, I5	PANEL / TERMINAL	ACS/ACH/ACT	I0, I5
I1...I4	PANEL / TERMINAL	INPS	I1...I4
I6...I8	PANEL / TERMINAL	ACH/ACT	I6...I8
I9...I12	PANEL / TERMINAL	CIN	I9...I12
K1...K8	CAR / TERMINAL	SCC/ACC	K1...K8
K9...K16	CAR / TERMINAL	ACC (INP)	K9...K16

When (←) button is pressed on the main screen or entered to the section (M1-VARIABLES→N5-INPUTS) then a number of screens which show the inputs are present. First two of them are for a quick view for states of all inputs. There are more screens which show the input terminals.

You can switch between screens with (↓) and (↑) buttons.

1) CONTROLLER INPUTS

In this screen you will see the inputs.

ACS Series

CONTROLLER INPUTS		
0-DER	3-501	
1-M0	4-500	
2-869	5-804	

ACH and ACT Series

T	0-DER	2-869
1	1-M0	* 3-501

The terminals ‘0’ and ‘5’ are I0 and I5 respectively on the main board. From 1 to 4 terminals are representing the terminals from I1 to I4 on the INPS board. Addition to that, in ACH and ACT series, number from 6 to 8 corresponds to I6..I8.

2) CAR INPUTS

ACS Series

CAR INPUTS 1		
1-M0	4-500	7-DTS
2-869	5-804	8-_____
3-501	6-K20	

ACH and ACT Series

K	1-M0	3-501
1	2-869*	4-500

This screen is visible only if serial communication with car has been established. It means that the parameter [A09] (M2-PARAMETERS→P1.MAIN PRMs→A09-COMMUNICATION METHOD) must be ‘1’ or ‘2’. The numbers on this screen represent the input terminals of car board.

1-D) DEFINITION OF INPUTS

i) DEFINE ALL IN ONE STEP

All programmable input terminals can be defined one by one. However, another facility is to program all input terminals in one step. In order to that, the menu at M2-PARAMETERS → P9-UTILITIES → R3-SET INPUTS can be used. It is recommended to use this utility when you want to organize the inputs as the first time. In case you want to change any single input terminal then it is better to do it as explained in the following section.

ACS Series

```
>G1-PARALLEL    M33
G2-SERIAL CAR
G3-FREE ALL
```

ACH and ACT Series

```
>G1-PARALLEL
G2-SERIAL CAR
```

The jobs of the selections are as follows:

G1-PARALLEL:

All inputs are organized as parallel connection system.

G2-SERIAL CAR :

All inputs are organized as car serial connection system.

G3-FREE ALL

All programmable input terminals are cleared to free input.

ii) SETTING OF INPUT TERMINALS

To modify the setting of an input terminal, first the screen on which the terminal is shown must be selected. For example, assume that we want to change the settings of the terminals on the INP board on main board. Firstly, we must bring CONTROLLER INPUTS / T1 on to the screen as shown below.

ACS Series

```
CONTROLLER INPUTS
0-M0_   3-501
1-MK_*  4-500
2-869   5-804
```

ACH and ACT Series

```
T1 0-M0_   2-869
    1-MK_*  3-501
```

When you see the screen above, then press ENT button. You will enter into the programming mode and the selected terminal is pointed by '>' character.

ACS Series

```
CONTROLLER INPUTS
0>M0_   3-501
1-MK_*  4-500
2-869   5-804
```

ACH and ACT Series

```
T1 0>M0_   2-869
    1-MK_*  3-501
```

You can select any terminal by using (↓) and (↑) buttons. When 'M0' is selected and we press (↓) button then the terminal 'MKU' which is just below 'M0' will be selected as shown below.

ACS Series

```

CONTROLLER INPUTS
0-M0_ 3-501
1>MK_* 4-500
2-869_ 5-804
    
```

ACH and ACT Series

```

T1 0-M0_ 2-869
    1>MK_* 3-501
    
```

To change the setting of any terminal, first find the input facility you want to connect to this terminal by tracing all possible inputs with (←) and (→) buttons. When you find the input you want for this terminal then press ENT button. Pressing ENT saves the data. You cannot connect any input facility, which is already used in any other terminal. If you attempt to do this then system warns you.

You can change any input terminal in all screens in this manner.

1-E) MAIN MENU

If you push ENT button on Main Screen, you will see the following Main Menu screen.

ACS Series

```

>M1-VARIABLES      M00
M2-PARAMETERS
M3-ERROR LOG
M4-LANGUAGE/DiL
    
```

ACH and ACT Series

```

>M1-VARIABLES
M2-PARAMETERS
    
```

We will see this kind of menus lots of times. The '>' (Pointer) character on most left column points a sub menu and if you want to enter pointed menu you must push ENT button. You can move '>' by using (↑) and (↓) up and down respectively. All menus in ACS Series have a menu number and this is shown at right top corner. The number of the Main Menu is M00 as seen above.

This menu has five sub-menus. In the first screen above you see only four of them. Use (↓) button to see the others. By this way, cursor moves one row down at each push. If you push (↓) button when the cursor at bottom row, all lines moves one row upper, the top line disappear and a new line comes from down as below:

ACS Series

```

M2-PARAMETERS      M00
M3-ERROR LOG
M4-LANGUAGE/DiL
>M5-SERVICES
    
```

ACH and ACT Series

```

M4-LANGUAGE/DiL
>M5-SERVICES
    
```

Instead of moving one step at each time you can use (→) button to see next four items and (←) button to see previous four items.

1-F) SETTING PARAMETERS

To see or change any parameter you must enter M2-PARAMETERS menu.

For example, let's set the parameter 'Number of Stops in System'. **At first, take the lift in inspection mode.**

ACS Series

```
M1-VARIABLES      M00
>M2-PARAMETERS
M3-ERROR LOG
M4-LANGUAGE/DiL
```

ACH and ACT Series

```
M1-VARIABLES
>M2-PARAMETERS
```

In Main Menu screen, use (↑) and (↓) buttons and when the pointer points 'M2-PARAMETERS' as above and push ENT button. If password is active, below screen appears. You cannot access parameters if you do not know password.

ACS Series

```
PASSWORD... ?000000_
```

ACH and ACT Series

```
PASSWORD...
?000000_
```

If you enter defined password or if password is not active, you will see M20 menu screen as below. When you enter password, you can access settings menu without any password entrance during 3 minutes.

ACS Series

```
>P1-MAIN PRMs    M20
P2-AUX. PRMs
P3-TIMINGS
P4-FLOOR PRMs
```

ACH and ACT Series

```
>P1-MAIN PRMs
P2-AUX. PRMs
```

When arrow is at P1-MAIN PRMs. line, press ENT and below screen appears if system is not in inspection mode.

ACS Series

```
PERMITTED ONLY IN
INSPECTION MODE!
```

ACH and ACT Series

```
PERMITTED ONLY
IN INSPECTION MO
```

Push ENT button again when the pointer points 'P1-MAIN PRMs' as above and system is in inspection mode. Then you see the first 4 items of Main parameters as below. This menu has 15 items as A01...A15. You can see other items by using arrow keys as described before. Some of the items in this screen are in abbreviated form. To see full form of any item, push ENT button when the pointer points it.

ACS Series

```

>A01-NUM.OF STOPS:6
A02-COMMAND      :4
A03-LIFT TYPE    :2
A04-DOOR TYPE    :2

```

ACH and ACT Series

```

NUMBER OF STOPS
A01:6

```

Push ENT again to change the [A01] parameter.

ACS Series

```

A01-NUMBER OF STOPS
?000006

```

ACH and ACT Series

```

A01 ?000006

```

Now, you see parameter change screen. In this type of screens, you always see six digit numbers. When you enter this screen firstly, cursor is always located under left most digit. You can increase or decrease value of the digit under which cursor is located by using (↑) and (↓) buttons respectively. You can move cursor to left and right by using (→) and (←) buttons.

In this screen, stored parameter data is 6 and cursor is located under digit (6). Now let us see some example about how to change value of a parameter.

```

?000006
(↓)
?000005
(↓)
?000004
(←)
?000004
(↑)
?000014

```

After setting the parameter, if you push ENT the new value on screen is saved. However if you push ESC, changes are cancelled. In both cases, you turn previous screen and see value of parameter.

Here we push ENT and see the following screen.

ACS Series

```

>A01-NUM.OF STOPS:14
A02-COMMAND      :4
A03-LIFT TYPE    :2
A04-DOOR TYPE    :2

```

ACH and ACT Series

```

NUMBER OF STOPS
A01:14

```

So we have changed number of floor in system as 14 and this change is stored in memory.

On this screen, let us change another parameter 'A02-COMMAND SYSTEM'. This parameter is in abbreviated form as 'A02-COMMAND SYSTEM'.

ACS Series

```
>A01-NUMBER OF S:14
  A02-COMMAND SYS:4
  A03-LIFT TYPE   :2
  A04-DOOR TYPE  :2
```

(↓)

```
  A01-NUMBER OF S:14
>A02-COMMAND SYS:4
  A03-LIFT TYPE   :2
  A04-DOOR TYPE  :2
```

(ENT)

```
A02-COMMAND SYSTEM
?000004
FULL COLLECTIVE
```

(↓)

```
A02-COMMAND SYSTEM
?000003
UP COLLECTIVE
```

(↓)

```
A02-COMMAND SYSTEM
?000002
DOWN COLLECTIVE
```

(ENT)

```
  A01-NUMBER OF S:14
>A02-COMMAND SYS:4
  A03-LIFT TYPE   :2
  A04-DOOR TYPE  :2
```

ACH and ACT Series

```
NUMBER OF STOPS
A01:14
```

(↓)

```
COMMAND SYSEM
A02:4
```

(ENT)

```
FULL COLLECTIVE
A02?000004
```

(↓)

```
UP COLLECTIVE
A02?000003
```

(↓)

```
DOWN COLLECTIVE
A02?000002
```

(ENT)

```
COMMAND SYSTEM
A02:2
```

Setting has been saved.

In the [A02] parameter change screens above, you see the information according to the value of parameter. You will see this type of information in some parameter change screens if changed parameter has a value of a type, system, shape etc. instead of number.

1-G) GIVING CALLS BY KEYPAD

In AC Series, it is possible to give cabin call by using keypad when lift is not in inspection mode.

Here is an example.

ACS Series

```
[SDL] [→←]      16:37
.....
[ 01=] [t__]STOP G+1
```

ACH and ACT Series

```
L 01=t__→←STOP :
.....
```

On Main Screen push (→)

ACS Series

```
Cabin Button
Floor No..  ?000002
```

ACH and ACT Series

```
Cabin Button
Floor No ?000002
```

In this screen, you can change floor number with arrow keys and when you push ENT, a cabin call is given.

1-H) SOFTWARE VERSION NUMBER

To see software version of your system on Main Screen, push and hold ESC. You see the following screen.

ACS Series

```
AYBEY ELEKTRONIK LTD
ACS Ver 1-16a
1685/200000      25°C
20/04/2015      19:16
```

ACH and ACT Series

```
AYBEY ACH1-16a
1685                25°C
```

Here '1-16a' shows software version of your system. Whenever you report any problem about lift operation then please always send information about software version you are currently using. You can also see date and time in this screen. When you release ESC button, system turns to Main Screen.

CHAPTER 2: PARAMETERS

All information about lift and control system settings and timings are stored in system parameters. These parameters are classified into several groups to make it easy for users. These groups are:

- **P1-MAIN PARAMETERS** : These are the most important and necessary parameters for lift to function properly. (Axx)
- **P2-AUXILIARY PARAMETERS** : This group includes secondary parameters for lift and the parameters about control system working conditions. (Bxx)
- **P3-TIMINGS** : These are timing parameters for lift. (Cxx)
- **P4-FLOOR PARAMETERS** : These are the parameters that can have different value for each floor.
- **P5-MAINTENANCE** : This is the date at which system requires maintenance.
- **P6-OUTPUT DEFINITION** : This parameters control user-defined relay outputs.
- **P7-INPUT DEFINITION** : This parameters control user-defined inputs.
- **P8-DATE/TIME** : Setting Real Time Clock and date.
- **P9-UTILITIES** : Some service routines.
- **P0-MAX-START** : Allowed number of maximum start of lift until next maintenance time.
- **PA-LIFT NO** : Lift number.

2-A) P1-MAIN PARAMETERS

System must set to inspection mode before any parameter changes!

[A01] NUMBER OF STOPS

2...64	This parameter stores the number of stops in lift system. When using parallel communication, be sure to have required I/O boards (IO) connected to the system for the selected command system in [A02]. Otherwise, no call is considered.
--------	---

[A02] COMMAND SYSTEM

0	<u>Simple Push Button</u> Car and hall call buttons are tied together. There is no call register memory. No second call is registered when the system deals with a call. No group operation is allowed. Hall calls are not allowed in busy state. (Only in parallel system)
1	<u>Simple Collective</u> Car and hall call buttons are tied together. Call register memory is present. There is no difference between hall and car calls. No group operation is allowed. (Only in parallel system)
2	<u>One Button Down Collective</u> Car and hall call buttons are connected separately. Car calls are collective in both directions where hall calls are collective when the lift moves downwards. This configuration is useful in residential buildings where the main entrance is in the base floor. Group operation is allowed.
3	<u>One Button Up Collective</u> Car and hall call buttons are connected separately. Car calls are collective in both directions where hall calls are collective when the lift moves upwards. This configuration is useful in residential buildings where the main entrance is in the top floor. Group operation is allowed.
4	<u>Two Buttons Full Collective</u> Car, up and down hall buttons are connected separately. Car and landing calls are all serviced in full collective manner. Group operation is allowed.

[A03] LIFT TYPE

1	<u>One Speed Rope Lift</u> (Only in ACT/ACS Systems)
2	<u>Two Speed Rope Lift</u> (Only in ACT/ACS Systems)
3	<u>Hydraulic Lift</u> (Only in ACH System)
4	<u>VVVF1</u> (Only in ACT/ACS Systems)
5	<u>VVVF2</u> (Only in ACT/ACS Systems)
6	<u>FUJI Closed Loop</u> (Only in ACT/ACS Systems)
7	<u>RST</u> (Only in ACT/ACS Systems)
8	<u>VVVF3</u> (Only in ACT/ACS Systems)
9	<u>KEB</u> (Only in ACT/ACS Systems)
10	<u>DIETZ</u> (Only in ACT/ACS Systems)
11	<u>FUJILIFT</u> (Only in ACT/ACS Systems)

[A04] DOOR TYPE

0	<u>Wing Door</u> Semi-automatic wing landing door, no cabin door
1	<u>Wing+Cabin Door</u> Semi-automatic wing landing door with automatic cabin door
2	<u>Full Automatic Door</u> Full automatic cabin and landing door

[A05] FLOOR SELECTOR SYSTEM

0	<u>Counter Mono-stable Shalter</u>
1	<u>Counter 1 Shalter (Only M0)</u>
2	<u>Counter 2 Shalters (M0 and M1)</u>
3	<u>Incremental Encoder</u>
4	<u>Absolute Encoder</u>
5	<u>Gray Code</u>
6	<u>Incremental Encoder + Shalter</u>

[A06] PREOPENING DOORS

0	<u>No</u> Doors are opened after motor has been stopped and brake has been released.
1	<u>Yes (FDT Active)</u> Doors are opened when the car entered the door zone of the target floor with a speed less than 0.3 m/s and when the FDT input is active. This operation is allowed only by using the special door bridging circuit SLB board. ML1 and ML2 shalters must be employed to get information about the door zone. The wiring and associated parameters are explained on the diagram of SLB board. (SLB is needed only with ACT/ACS)
2	<u>Yes (No FDT)</u> FDT input is not checked for preopening doors. (Only in ACT/ACS Systems)

[A07] LEVELING

0	<u>No</u>
1	<u>Open Door/Mot+</u>
2	<u>Closed Door/Mot+</u> (<i>Only in ACH System</i>)
3	<u>Open Door/Mot-</u> (<i>Only in ACH System</i>)
4	<u>Closed Door/Mot-</u> (<i>Only in ACH System</i>)

[A08] NUMBER OF DOORS IN CABIN

1	<u>1 Door</u>
2	<u>2 Doors</u> Make your selections of driven doors for each floor in M2-PARAMETERS → P4-FLOOR PRMs. → K2 and K3

[A09] CONTROLLER-SHAFT COMMUNICATION

0	<u>Parallel</u> (<i>Only in ACH/ACT Systems</i>) Parallel communication between controller and car/landing panels. One to one cable is connected between controller terminals and signals or buttons.
1	<u>Car Serial</u> (<i>Only in ACH/ACT Systems</i>) Serial communication between lift controller and car. Landing panels are connected as in parallel mode.
2	<u>Serial</u> Full serial communication is being done by CANBUS communication network between lift controller, landing panels and car. CSI board is needed for ACH/ACT series.

[A10] NUMBER OF STOPPERS

0	<u>1 Stopper (MK)</u> (<i>Only in ACH/ACT Systems</i>)
1	<u>2 Stoppers (MKU and MKD)</u> If lift type is selected as hydraulic ([A03]=3) where the driven force in up and down directions is different, then the system automatically uses this selection. This option may also be used in other lift types besides hydraulic.

[A11] HIGH SPEED (*Only in ACT/ACS Systems*)

0	<u>No</u>
1	<u>Use 3th. Speed HIGH</u> (<i>Only in VVVF</i>) This option is used in variable speed lifts where the car speed exceeds 1m/s. In this case, the lift has slow, fast and high (3 th speed) speeds. When this case is selected then HU shalter must be placed one floor below the top floor and HD shalter must be placed one floor above the base floor. The purpose of these shalters is to slow down the car from high speed (3th. speed) to intermediate speed (fast speed) in order to prevent the car to enter last floors of the shaft with a speed above 1.6 m/s or higher. If this case is selected without connecting HU and HD then an error message (21) is reported.
2	<u>Use 4th. Speed ULTRA</u> (<i>Only in VVVF</i>) It is active only when [A18] = 1

[A12] SIMPLEX/GROUP

0	<u>Simplex</u> The lift works alone.
1	<u>Group</u> The lift works in a group of lifts.

[A13] GROUP NUMBER

0...7	Lift group identifier. Each lift in the group must have a unique identifier between 0...7. The one which has smallest number as identifier manages the network and responsible for reading call buttons and driving call register lamps.
-------	--

[A14] MISSING FLOOR BELOW (GROUP LIFT)

0...5	The difference of the base floor to the lowest floor in the group.
-------	--

[A15] MISSING FLOOR ABOVE (GROUP LIFT)

0...5	The difference of the top floor to the highest floor in the group.
-------	--

[A16] ENTRANCE FLOOR

0...8	When there are some stops under entrance floor such as basement or garage, set this parameter that is valid only if command system is down collective (A02=2). The calls over entrance floor are collected during down travel and the calls under entrance floor are collected during up travel.
-------	--

[A17] UCM CONTROLLER

0	<u>Not Present</u>
1	<u>GMV NGV – A3</u>
2	<u>BUCHER DSV – A3</u>
3	<u>Gearless</u>
4	<u>Speed Governor 1</u> (Monitoring both SGO and SGC inputs)
5	<u>BLAIN L10 – A3</u>
6	<u>Speed Governor 2</u> (Monitoring only SGO input)
7	GMV 3010 DLV-A3
8	BUCHER iValve
9	OMAR HI-Valve

[A18] TARGET DISTANCE

0	<u>Floor Number</u> When ([A11]=1 and target is 2 stops or more then lift starts in HIGH speed and passes to SLOW speed when it reached the target.
1	<u>Distance</u> Controller calculates total distance to the target considering the parameters K7-GENERAL PULSES> MIN.WAY-3, MIN.WAY4 and DECELERATION-2. It chooses starting speed according to [A11] parameter. For deceleration K7-GENERAL PULSES> DECC.-2, DECC.-3 and DECC.-4 parameters are taken into account.

[A19] HOMELIFT

0	<u>Normal Lift</u>
1	<u>Homelift</u> Motion occurs from cabin when the call button hold pressed along motion. If button released, then motion stop immediately. However system operates same as normal mode from landing calls.

2-B) P2-AUXILIARY PARAMETERS

[B01] AFTER LOCK FAILURE

0	<u>Continue</u> The system continuous operation
1	<u>Block When Repeated</u> The system is blocked if the number of consequent errors has been repeated as the number stored in the parameter [B12].
2	<u>Clear Registers</u> All call registers are cleared.
3	<u>Block+Try Again</u> The system is blocked if the number of consequent errors has been repeated as the number stored in the parameter [B12]. System returns normal mode after 5 minutes.

[B02] ERROR REPORT

0	<u>Single Line Report</u> When an error occurs, the current screen is not left. Only when the screen is the main screen then a flashing message about the error is displayed. The details can be analyzed in M3-ERROR LOG
1	<u>Full Screen Report</u> When an error occurs, the current screen is left and error screen is displayed where all the information about the error is given. After a few seconds of display time, previous screen restored.

[B03] PARK DEFINITION

0	<u>No Park Floor</u> No park floor is defined.
1	<u>Park Floor Door Closed</u> When the lift is in park at this floor then it will wait there with <u>closed</u> doors.
2	<u>Park Floor Door Open</u> When the lift is in park at this floor then it will wait there with <u>open</u> doors. (Not conformity with EN81-1 and EN81-2)

[B04] PARK FLOOR

0...63	Park floor number. When [B03] is 1 or 2 and the lift has no calls about the time defined in [C02] then lift moves to this floor and stays there until a call comes with the door opening state specified in [B03].
--------	--

[B05] FIRE FLOOR 1

0...63	Fire floor no. When the fire input of the lift is activated then the car immediately moves to this floor.
--------	---

[B06] MAXIMUM CABIN CALLS

1...64	Maximum number of allowable cabin calls.
--------	--

[B07] BREAKPOINT CODE

0	Only for service of the operating system. Leave it as 0.
---	--

[B08] CONTINUE ON ERRORS

0	<u>No</u> The system stops after all errors.
1	<u>Yes</u> The system continues its operation after some simple errors, which are not about safety circuit or related with car motion.

[B09] WAIT DOOR OPEN

0	<u>Wait With Closed Door</u> Car waits with closed doors in floor.
1	<u>Wait With Open Door</u> Car waits with opened doors in floor for automatic doors. . (Not conformity with EN81-1 and EN81-2)
2	<u>Stop With Open Door</u> Only it opens with K20 Button

[B10] REMOTE REPORTING

0	<u>Not Activated</u>
1	<u>PC</u>
2	<u>GSM SMS</u> After an error, system sends a SMS to defined phone number.
3	<u>GSM CALL</u> After an error, system calls defined phone number and after 5 second hangs up the line.
4	<u>ERR > CALL ALR > SMS</u> System calls defined phone number in case of an error and sends SMS on Alarm.
5	<u>ERR > SMS ALR > CALL</u> System sends SMS to defined phone number in case of error and calls on Alarm.

[B11] LANGUAGE

0	<u>Turkish/Turkce</u>
1	<u>English/İngilizce</u>
2	<u>German/Deutsch</u>
3	<u>Greek/Ελληνικά</u>
4	<u>Russian/Россия</u>
5	<u>French/Francais</u>
6	<u>Spanish/Espanol</u>

[B12] MAXIMUM ERRORS REPEAT

4...100	When any error with the error code 7, 8, 27, 28, 34, 35, 36, 37, 38 and 41 is repeated as the number stored in this parameter then the system blocked.
---------	--

[B13] SERIAL PORT 1

0	<u>Closed</u>
1	<u>PC Communication</u>
2	<u>GSM MODEM</u>
3	<u>ERS</u>

[B14] SERIAL PORT 2 (Only in ACS System)

0	<u>Closed</u>
1	<u>PC Communication</u>
2	<u>GSM MODEM</u>
3	<u>ERS</u>

[B15] SERIAL PORT 3 (Only in ACS/ACT System)

0	<u>Closed</u>
1	<u>PC Communication</u>
2	<u>GSM MODEM</u>
3	<u>ERS</u>

[B16] SERIAL PORT 4 (Only in ACS System)

0	<u>Closed</u>
1	<u>PC Communication</u>
2	<u>GSM MODEM</u>
3	<u>ERS</u>

[B17] HALL CALLS INHIBIT

0	<u>Hall Calls Allowed</u>
1	<u>Hall Calls Inhibited</u>

[B18] TWO DOORS SELECTION

0	<u>Not Used</u> The parameters given in Floor Parameters section are valid for door selection at each floor.
1	<u>Terminal Input</u> The door to be opened at each floor is determined by the programmable inputs, DOA and DOB.

[B19] AFTER STOP FAILURE

0	<u>Continue</u> System continues to work.
1	<u>Clear Registers</u> All of the call registers are cleared and the system continues to work.

[B20] INSPECTION SPEED

0	<u>Fast (Hydraulic)</u> Inspection speed is high speed. (Only in ACH System)
1	<u>Slow</u>
2	<u>Only Direction</u> When there is a motion command in inspection mode then only direction command is sent, neither slow nor high speed is activated.

[B21] THERMOMETER

0	<u>No Temp. Control</u>
1	<u>Onboard Detector</u>
2	<u>THR Input</u>

[B22] INSPECTION SWITCH

0	Closed contact in inspection mode.
1	Open contact in inspection mode.

[B23] PTC CONTROL

0	<u>OFF</u>
1	<u>ON</u>

[B24] PHASE CONTROL

0	<u>OFF</u>
1	<u>Onboard</u>
2	<u>FKI Input</u>
3	<u>One phase</u>
4	<u>No checking for phase order</u> (ACH and ACS)

[B25] HYDRAULIC STOP STYLE (*Only in ACH System*)

0	<u>Valve-Motor Delay</u> In hydraulic lift operation, when a stop command is processed then valves are deactivated immediately. Motor is stopped after a delay specified in parameter [C15].
1	<u>Motor-Valve Delay</u> In hydraulic lift operation, when a stop command is processed then motor is deactivated immediately. Valves are stopped after a delay specified in parameter [C15].

[B26] ERS MOTOR INVERTER (*Only in ACS/ACT Systems*)

0	<u>Not Activated</u> There is no motor inverter in emergency rescue operation.
1	<u>Activated</u> There is a motor inverter whose running direction is defined by contactors.
2	<u>Activated-All Direction</u> There is a motor inverter whose running direction is defined by EMD board itself.
3	<u>APS+EMD</u> UPS + Battery. Motor is driven by EMD board.

[B27] BACKLIGHT

0	<u>Auto Off</u> Energy saving mode. The backlight illumination of the LCD screen of the controller is switched off when not used.
1	<u>Always On</u> The backlight illumination of the LCD screen of the controller is always ON.
2	<u>Always Off</u> The backlight illumination of the LCD screen of the controller is always OFF.

[B28] ERS RESCUE SPEED

0	<u>Fast+Inspection</u> Fast and Inspection signals are both active.
1	<u>Fast</u> Only fast signal is active.
2	<u>Slow</u> Motor inverter exists for rescue mode. Direction is chosen by ERS board.
3	<u>Slow+Inspection</u> To rescue with UPS and battery. Motor is driven by EMD board.

[B29] HALF LOAD CURRENT (ERS) (*Only in ACS/ACT Systems*)

1...60	The current measured in emergency rescue operation where car load is one half of the nominal load.
--------	--

[B30] MAXIMUM CURRENT (ERS) (*Only in ACS/ACT Systems*)

2...100	The maximum allowed current in emergency rescue operation.
---------	--

[B31] ACCESS CONTROL

0	<u>Not Used</u>
1	<u>Cabin</u>
2	<u>Cabin+Controller</u>
3	<u>Cabin+Controller+PC</u>

[B32] GONG SELECTION

0	<u>Gong When Stopped</u>
1	<u>Gong on Slow Speed</u>
2	<u>No Gong</u>

[B33] DOOR AT STOP

0	<u>Doors Active</u> Door signals are active if Stop (120) is cut. Automatic door signals remains active.
1	<u>Doors Passive</u> Door signals are passive if Stop (120) is cut. (Last door command remains)

[B34] MK SWITCH

0	<u>Open at Floor</u>
1	<u>Closed at Floor</u>

[B35] MK DELAY

0...90	This parameter is especially designed for VVVF and slow-speed pulley good lifts to set fine-tuning at landing level. It is the time after reading MK switch until stop. Parameter unit is 30 msec. Setting 0 disables the delay. Setting max. value of 90 causes 2.7 sec delay.
--------	---

[B36] BLOCKING CONTROL

0	<u>Blocking Allowed.</u> Only in ERROR 45(Bridging Error).
1	<u>Blocking Inhibited</u> (Not conformity with EN81-1 and EN81-2) Only in ERROR 45(Bridging Error).

[B37] ENCODER RATIO (*Detailed information is in Encoder Installation Manual*)

0...100	Encoder pulse divider ratio
---------	-----------------------------

[B38] CAR DISPLAY OUTPUT

0	<u>7 Segment Display</u>
1	<u>Gray Code</u> Digital display outputs on SCC and ACC board operate as G-G0, F-G1, E-G2, D-G3 gray code outputs.
2	<u>Binary Code</u> Digital display outputs on SCC and ACC board operate as G-B0, F-B1, E-B2, D-B3 binary code outputs.

[B39] HALL DISPLAY OUTPUT

0	<u>7 Segment Display</u>
1	<u>Gray Code</u> Digital display outputs ACPK board operate as G-G0, F-G1, E-G2, D-G3 gray code outputs.
2	<u>Binary Code</u> Digital display outputs on ACPK board operate as G-B0, F-B1, E-B2, D-B3 binary code outputs.
3	<u>Floor Signal</u> Digital display outputs on ACPK board operate as A-701, B-702...G-707, 2G-708, 2BC-709 floor signal outputs.

[B40] FIRE FLOOR 2

0...63	Fire floor 2 number. When the Fire 2 input of the lift is activated then the car immediately moves to this floor.
--------	---

[B41] PRIORITY SYSTEM

0	<u>Not Activated</u>
1	<u>Activated</u>

[B42] MACHINE ROOM MINIMUM TEMPERATURE

0...9	Minimum working temperature
-------	-----------------------------

[B43] MACHINE ROOM MAXIMUM TEMPERATURE

30...60	Maximum working temperature
---------	-----------------------------

[B44] DATE AND TIME

0	<u>Not Activated</u>
1	<u>Activated</u>

[B45] ERS MK DELAY

0...120	MK delay in ERS mode
---------	----------------------

[B46] FIREMAN LIFT

0	<u>EN81-73</u>
1	<u>EN81-72</u>
2	<u>EN81-72 Car Key</u>
3	<u>EN81-72 Russian Standard</u> a) When system is in fire mode and controlled by fireman, system accepts register if button hold pressed until door close operation finished. Otherwise system neglects the register and opens the doors again. b) Last step of passing to normal mode from fire mode, take system to inspection mode and normal mode again.

[B47] CAN0 OUTPUT SELECTION

0	<u>Shaft Communication</u>
1	<u>Input Board CIN</u>
2	<u>Output Board EOR</u>

[B48] CAN1 OUTPUT SELECTION

0	<u>Group Communication</u>
1	<u>Input Board CIN</u>
2	<u>Output Board EOR</u>

[B49] CAN2 OUTPUT SELECTION (Only in ACS System)

0	<u>CAN Communication</u>
1	<u>Input Board CIN</u>
2	<u>Output Board EOR</u>

[B50] LIMITS OF MOTION IN INSPECTION

0	<u>High Speed Limit</u> If lift is in inspection mode from cartop (869), travel limits are 817/KSR1 and 818/KSR2 limit shalters.
1	<u>Floor Level</u> If lift is in inspection mode from cartop (869), travel limits are top and bottom floor levels. Note: Check floor levels before setting this parameter.

[B51] BUTTON FAULT CONTROL

0	<u>Not Activated</u>
1	<u>Activated</u> When any call register button in parallel connection system hold pressed more than 300 sec, then system cancels related button input until lift pass to inspection mode and returns to normal mode again.

[B52] VVVF LEVEL SPEED

0	<u>Slow Speed</u>
1	<u>Special</u> (System use output 23-Leveling Motion as leveling speed)

[B53] DIRECTION ARROWS

0	<u>Direction</u>
1	<u>Next Direction</u>

[B54] HYDRAULIC TOP STOP FAULT

0	<u>Activated</u> If car exceeds top floor level and cut Top Limit STOP (120), then system reports Error 55 : "Hydraulic Top Limit Error" in hydraulic lifts. Car returns to bottom floor when stop circuit is normal. Door open and closed at bottom floor then lift pass to out of service mode. De-energize and then energize system or pass to inspection mode to reset.
1	<u>Not Activated</u>

[B55] 1st VIP FLOOR

0...63	When the VP1 input of the lift is activated then the car immediately moves to this floor.
--------	---

[B56] 2nd VIP FLOOR

0...63	When the VP2 input of the lift is activated then the car immediately moves to this floor.
--------	---

[B57] 3th VIP FLOOR

0...63	When the VP3 input of the lift is activated then the car immediately moves to this floor.
--------	---

[B58] SPEED GOVERNOR COIL

1	<u>On In Motion</u>
2	<u>Always On</u>
3	<u>Always On+Sleep</u>

[B59] UCM CHECK TYPE

1	<u>Starting Count</u>
2	<u>Daily Control</u>

[B60] DOOR RELAY OUTPUT (KA, KK relays on mainboard)

0	<u>Door Relays (Drives 1st. Door)</u>
1	<u>Programmable</u>

[B61] RESETTING SHALTER

0	<u>Not Used</u>
1	<u>Terminal Input</u> This selection operates if [A05] parameter is 3 or 6 and [A18] is 1. If there is more than one floor below 817/KSR1 or above 818/KSR2, then system use this terminals for floor number reset. 917 is for bottom floor and 918 is for top floor.

[B62] ERS LAST STEP

0	<u>Door Opening</u> At the end of rescue operation door is opened.
1	<u>Door Closing</u> At the end of rescue operation door is closed.

[B63] LCD 2nd.CHAR SET

0	<u>Japanese (Standard)</u>
1	<u>Russian (Cyrillic)</u>

[B64] UCM ERROR BLOCK

0	<u>Blocking Allowed.</u> Block the system in case of UCM Errors (64,68,69 and 72)
1	<u>Blocking Inhibited (Not conformity with EN81-1/2+A3 Norm)</u> Don't Block the system in case of UCM Errors (64, 68, 69 and 72)

[B65] ENCODER DIRECTION (Incremental Encoders)

0	<u>Phase A leads</u>
1	<u>Phase B leads</u>

2-C) P3-TIMINGS

In all of the C type parameters (timings), one unit corresponds to 0.1 sec.

[C01] BUSY PERIOD

20...999	Busy period in which cabin light and Busy output (12) are activated.
----------	--

[C02] PARK WAIT TIME

0...9999	This parameter stores the period of the car to move park floor.
----------	---

[C03] OPEN WAIT PERIOD

0...500	This parameter stores the period of the automatic door to wait open before closing.
---------	---

[C04] DOOR OPEN PERIOD

0...999	This parameter stores the period of the automatic door to open.
---------	---

[C05] DOOR LOCK WAIT PERIOD

0...999	This parameter stores the period of the automatic door to close. This parameter is controlled by checking lock (terminal 140) after door close command.
---------	---

[C06] IN FLOOR WAIT PERIOD

20...999	This parameter stores the period of the car to wait before departing for the next call in collective systems.
----------	---

[C07] STARTUP DELAY

0...100	It stores the time delay of the car to wait before departure after lock contact is closed.
---------	--

[C08] FAST MAXIMUM PERIOD

0...9999	This parameter stores the maximum time allowed to pass without changing the current floor number when the car is in fast or high speed (in 3 speed systems). When this timer overflows, then an error is generated and the system is blocked.
----------	---

[C09] SLOW SPEED MAXIMUM PERIOD

0...999	This parameter stores the maximum travel time allowed to pass when the car is in slow speed. When this timer overflows, then an error is generated and the system is blocked.
---------	---

[C10] ARCH TRAVEL

0...999	Designed for the system where the distance between two stops is very short. At startup, during this period lift doesn't pass from high speed to slow speed.
---------	---

[C11] GROUP DOOR OPEN WAIT PERIOD

6...999	When the lifts work in group, then this parameter specifies the maximum time period in which a lift can hold a hall call as its target and its doors are forced to stay open. After timeout of this period, the hall call is left free where any other member of the group can take it as a target.
---------	---

[C12] BRAKE DELAY TIME

13...100	Brake delay in ACVV and VVVF systems. This parameter defines the time delay of programmable relays for selection number 25, 27 and 51.
----------	--

[C13] MOTOR VALVE DELAY TIME (*Only in ACH System*)

0...99	This parameter determines the delay time between the motor starts to run and the valves are activated in hydraulic lifts in startup.
--------	--

[C14] STAR DELTA SWITCHING PERIOD (Only in ACH System)

0...99	This parameter determines the switching time of the motor from star connection to delta connection in hydraulic lifts in startup.
--------	---

[C15] VALVE MOTOR DELAY TIME (Only in ACH System)

0...99	This parameter is used only in hydraulic lifts and determines the delay time between valves and the motor (or vice versa) after a stop command. See parameter [B25] for better understanding.
--------	---

[C16] MAXIMUM BUSY TIME

0	Inactive
1...9999	If the doors are left open or cannot close during a period of [C16] then the busy signal and cabin light are off until a new call is received.

[C17] PAWL MOTION UP

0...999	This period specifies the period of special pawl up motion when the lift starts for any direction.
---------	--

[C18] PAWL LOCK WAIT

0...999	The maximum waiting period after energizing the PAWL device until SKN is read ON.
---------	---

[C19] PAWL PRESSURE WAIT

0...999	The maximum period for KNB to be read as ON after starting special PAWL motion in starting phase of the lift.
---------	---

[C20] DTS BUTTON DELAY

0	Disabled
1...150	DTS (Door close button) is inhibited during the period given in this parameter. The period starts when the car reaches the floor.

[C21] MAXIMUM MOTION WAIT PERIOD

0...100	If there is no signal in programmable input with code 10 (RUN) within the time period specified in this parameter after a motion command is received, then the system is stopped. If RUN input is not defined then this timer is not active.
---------	--

[C22] RETIRING CAM DELAY

0...160	Period to delay the activation of retiring cam after the landing door has been closed for semi-automatic systems.
---------	---

[C23] LEVEL OVERFLOW

0...500	If the leveling process cannot be completed within the period specified in this parameter then an error (41) is generated and leveling in this floor is not allowed any more until the car moves to a different floor.
---------	--

[C24] DOOR OPEN DELAY

0...35	Delay period of an automatic door to start opening after reaching the floor.
--------	--

[C25] MAXIMUM ERS PERIOD

600...5000	Maximum allowed period of emergency rescue operation.
------------	---

[C26] FAST DELAY TIMER

0...99	Delay period of the fast contactor to be activated during starting phase.
--------	---

[C27] DIRECTION DELAY

0...110	Delay period to allow the direction to change after stopping.
---------	---

[C28] MAXIMUM MOTOR TIME

200...3000	Maximum period in which motor is allowed to work. (To set this parameter more than 450 (45 sec) is not conformity with EN81 standards)
------------	---

[C29] ERS DOOR OPEN PERIOD

20...300	Maximum period in which the door should be opened in emergency rescue operation after arriving to floor.
----------	--

[C30] K20 PERIOD

6...200	This period defines the period of automatic door driven in open direction when K20 input is activated. It can be set between 0.6 sec. and 8 sec.
---------	--

[C31] K22 PERIOD

6...200	This period defines the period of automatic door 2 driven in open direction when K22 input is activated. It can be set between 0.6 sec. and 8 sec.
---------	--

[C32] LOADING PERIOD

0...9999	It defines the period during which automatic door hold open. This parameter is active when LDB input is defined and runs independent from photocell and door-open push-button.
----------	--

[C33] ENCODER CONTROL

20...99	Encoder signal check period after last signal receive.
---------	--

[C34] CONTACTOR DELAY

0...10	Star to delta connection pass delay.
--------	--------------------------------------

[C35] PRIORITY PERIOD

300...3000	Priority wait period.
------------	-----------------------

[C36] CAM DELAY

0...60	Cam delay period.
--------	-------------------

[C37] UPS-ERS DELAY

50...500	UPS delay period in ERS start mode.
----------	-------------------------------------

[C38] AGS DELAY

100...9999	AGS input delay period.
------------	-------------------------

[C39] EARLY DOOR DELAY

0...50	Early door delay period.
--------	--------------------------

[C40] MAXIMUM OPEN STATE

0...3000	Maximum door open period. Output 88 will be activated if door open state period is more than this parameter.
----------	--

[C41] GONG PERIOD

10...200	Period of gong signal output.
----------	-------------------------------

[C42] SPEED GOVERNOR STOP DELAY

0...80	Overspeed governor A3 coil releasing delay after stop.
--------	--

[C43] ERS START WAIT

0...200	Waiting period to start motion in ERS mode.
---------	---

[C44] PHOTOCCELL PERIOD

20...500	Door-open wait period after receiving signal from photocell.
----------	--

[C45] MI RUN DELAY

0...30	Run delay for EMD board after FAST command received in ERS mode.
--------	--

[C46] 2CH/S VALVE DELAY

0...35	GMV 3010 2CH/S type valve's delay time for stopping
--------	---

2-D) P4-FLOOR PARAMETERS

In this section, you can program the parameters of the system that may be different for each floor. We name these parameters as “Floor Parameter”. In screen M20, item P4 is the selection for floor parameters. If you select P4 and press (ENT) key then the following screen is displayed.

ACS Series

```
>K1-SET DISPLAYS M24
K2-SET DOOR A
K3-SET DOOR B
K4-CAR CALLS
```

ACH and ACT Series

```
>K1-SET DISPLAYS
K2-SET DOOR A
```

Menu M24 consists of the following sections:

```
K1-SET DISPLAYS
K2-SET DOOR A
K3-SET DOOR B
K4-CABIN CALLS
K5-HALL CALLS
K6-FLOOR PULSE
K7-GENERAL PULSE
K8-CALL PERIODS
```

2-D-1) K1-SET DISPLAYS

In this section, you see the following screen:

ACS Series

```
00.FLR DISPLAY: -1
>01.FLR DISPLAY: 0
02.FLR DISPLAY: 1
03.FLR DISPLAY: 2
```

ACH and ACT Series

```
00.FLR DISP: -1
>01.FLR DISP: 0
```

When you select any floor by pressing (ENT) key, then you can enter the digital display data by using the following display input screen:

ACS Series

```
01.FLR DISPLAY:
LEFT: _ RIGHT: 0
(↑↓ SCAN CHARACTERS)
```

ACH and ACT Series

```
01.FLR DISPLAY:
LEFT: _ RIGHT: 0
```

This screen is designed to set left and right digital characters. When you enter this screen first, the cursor is waiting just after ‘LEFT:’. Here either you can skip this field by pressing (ENT) key and accepting the character shown there or select the character by using (↑) or (↓) keys. As you scan characters, all ASCII characters will be displayed one by one. You can select any of one you want to be displayed in car and landing panels.

However, the hardware you are using to drive and display these characters limits the characters you actually see on the displays. For example if you have 7-segment digital displays on your panels then you can see the characters of all digits from 0 to 9 and other characters like -, A, b, C, d, E, F, H, I, J, L, n, P, r, U, y. If you have such hardware in your system then you cannot see any characters like M or X on panels if you select them. However, if you have dot matrix displays and its driving hardware is connected in your system then you can actually display all characters you select in this section.

After you have chosen the character you want on the left display, press (ENT) key to go to the input field of the right display. You can select the right side display by using (↑) or (↓) keys as previous field. After you have chosen the character that you want on the right display, press (ENT) key to return back to previous menu.

By using the same procedure, you can specify all floor displays for your lift system.

This section is to change display data for any floor. However, if you want to reorganize your displays in an ordered manner, then you can use special utilities. You can go to this section from M20 menu P9-UTILITIES→R1-DISPLAY UTIL. In this utilities section the following screen is waiting for an input:

ACS Series

```

BASE FLOOR NO :
?000000_
    
```

ACH and ACT Series

```

BASE FLOOR NO :
?000000_
    
```

You can change the data by using (↑) and (↓) keys between 0 and maximum floor number. If you specify which floor is the entrance floor of the building, then this utility sets the digital display of the entrance floor (base floor) as 0. All floors above this floor are numbered starting 1 and incremented by 1 at every floor; all floors below 0 (base floor) are numbered starting -1 and decremented by 1 at every floor. If you have a regular display order in your system with a few exceptions then first use the utility explained above and then changes the data for exceptional floors one by one.

2-D-2) K2-SET DOOR A and K3-SET DOOR B

This section is designed to select active automatic door(s) at each floor. If the system has only one door, then you cannot use this section. In order to set the data given in this section, number of automatic doors [A08] in cabin must be 2.

ACS Series

```

00 . FLR DOOR A : 1 ON
>01 . FLR DOOR A : 0 OFF
02 . FLR DOOR A : 1 ON
03 . FLR DOOR A : 1 ON
    
```

ACH and ACT Series

```

00 . FLR DOOR A : 1
>01 . FLR DOOR A : 0
    
```

If the system has two doors, then they are named as A and B. If your system has two doors in cabin, you can select freely which doors will open in each floor. When you see '1' as data, then it means that this door will open at this floor. When you see '0' as data then it means that this door will not open at this floor. In order to change the condition of the door for a specific floor, press (ENT) key in the line of this floor. In the following screen you can change the data by using (↑) and (↓) keys between 0 (NO) and 1 (YES).

ACS Series

```

01.FLOOR DOOR A
?000000
NO

```

ACH and ACT Series

```

01.FLOOR KAPI A
?000000 OFF

```

In this screen, the data for 1st floor is displayed as NO. It means that door A will not open at 1st floor. Here 0 is for OFF and 1 is for ON.

For door B, the same procedure applies for item K3.

2-D-3) K4-CABIN CALLS

You can set cabin calls allowance for any floor by using this section. If you switch off cabin call of any floor then any call coming from car operating panel will be discarded. When you enter this section by pressing (ENT) key in menu M24 then you see the following screen.

ACS Series

```

00.CABIN CALL:1 ON
>01.CABIN CALL:2 PE1
02.CABIN CALL:3 PE2
03.CABIN CALL:0 OFF

```

ACH and ACT Series

```

00.CABIN CALL:1
>01.CABIN CALL:2

```

In order to select a floor to change its data, press (ENT) key in its line. Then you see the following edit screen. You can change the data by using (↑) and (↓) keys between 0 and 3.

ACS Series

```

03.FLOOR CABIN CALL
?000000
OFF

```

ACH and ACT Series

```

03.CABIN CALL
?000000 OFF

```

The parameters used in this screen are as follows

0	<u>OFF</u> A cabin call for this floor is not allowed
1	<u>ON</u> A cabin call for this floor is always allowed.
2	<u>PE1</u> If the clock time is within the time interval PERIOD1 which is specified in section K8, then the cabin call is allowed, otherwise not allowed.
3	<u>PE2</u> If the clock time is within the time interval PERIOD2 which is specified in section K8, then the cabin call is allowed, otherwise not allowed.

2-D-4) K5-HALL CALLS

You can set hall calls allowance for any floor by using this section. If you switch off hall call of any floor, then any call coming from landing operating panel will be discarded. When you enter this section by pressing (ENT) key in menu M24, then you will see the following screen.

ACS Series

```
>00.HALL CALL: 1 ON
01.HALL CALL: 0 OFF
02.HALL CALL: 1 ON
03.HALL CALL: 3 PE2
```

ACH and ACT Series

```
>00.HALL CALL:1
01.HALL CALL:0
```

In order to select a floor to change its data, press (ENT) key in its line. Then you see the following editing screen. You can change the data by using (↑) and (↓) keys between 0 and 3.

ACS Series

```
00.HALL CALL
?000001
ON
```

ACH and ACT Series

```
00.HALL CALL:
?000001 ON
```

The parameters used in this screen are as follows

0	<u>OFF</u> A hall calls for this floor is not allowed
1	<u>ON</u> A hall calls for this floor is always allowed.
2	<u>PE1</u> If the clock time is within the time interval PERIOD1 that is specified in section K8, then the hall calls are allowed, otherwise not allowed.
3	<u>PE2</u> If the clock time is within the time interval PERIOD2 that is specified in section K8, then the hall calls are allowed, otherwise not allowed.

2-D-5) K6-ENCODER PULSE OF FLOORS

If you select as floor selector 3 (incremental encoder) or 4 (absolute encoder) in [A05], then you can enter this section and edit pulse data for any floor.

ACS Series

```
>00.FLR PULSE:1000
01.FLR PULSE:4000
02.FLR PULSE:7000
03.FLR PULSE:10000
```

ACH and ACT Series

```
>00.FLR: 1000
01.FLR: 4000
```

In order to select a floor to change its data, press (ENT) key in its line. Then you see the following editing screen.

ACS Series

```
02.FLR PULSE:
?002468
```

ACH and ACT Series

```
02.FLR PULSE:
?002468
```

You can change the data by using (↑) and (↓) keys. In order to go from column to column, use (←) and (→) keys.

2-D-6) K7-GENERAL PULSE

This parameter is used only if [A05] is 3 (incremental encoder) or 4 (absolute encoder). The parameters given in this section correspond to the distances that are used for all floors. When you change any pulse number, then the distance for the related path is changed in all floors. All of the data given in this section are the distances in encoder pulses to the floor level specified in the previous section.

ACS Series

```
MKD STOPPER
MKU STOPPER
SLOW DOWN
>DOOR ZONE
```

ACH and ACT Series

```
MKD STOP :12
>MKU STOP :12
```

MKD STOPPER: The distance in pulses between the exact floor level and the point of stop command when two stoppers ([A10]=1) are used while moving downwards.

MKU STOPPER: The distance in pulses between the exact floor level and the point of stop command when two stoppers are used while moving upwards.

SLOW DOWN: The distance in pulses where the controller switches to low speed when it reaches its target floor.

DOOR ZONE: The distance in pulses from the exact floor level to the level in which the automatic door can be opened. The pulse number given in this parameter applies from the floor level up and down.

LEVELING START: The start limit of releveling zone in pulses. The controller activates releveling process when the lift exceeds pulse that specified with this parameter.

LEVELING STOP: The stop limit of releveling zone in pulses. The controller deactivates releveling process when the lift distance from floor level pulse is under than specified with this parameter.

MK LENGTH UP: The distance between car and floor when the MK shalter is active while moving upwards.

MK LENGTH DOWN: The distance between car and floor when the MK shalter is active while moving downwards.

DECELERATION 3th SPEED: The minimum distance in which lift can pass from HIGH speed to SLOW speed.

DECELERATION 4th SPEED: The minimum distance in which lift can pass from ULTRA speed to SLOW speed.

MINIMUM WAY 3th SPEED: The minimum distance in which lift can reach HIGH speed and slow down.

MINIMUM WAY 4th SPEED: The minimum distance in which lift can reach ULTRA speed and slow down.

2-D-7) K8-CALL REGISTER PERIODS

ACS Series

```
>PERIOD1 08:30-12:30
PERIOD2 13:30-18:30
```

ACH and ACT Series

```
PE1 08:30-12:30
PE2 13:30-18:30
```

You can specify two periods in this section. The first one is used as the period PE1 and the second is PE2 in sections K5 and K6 where call register allowance is specified. Here the data given are 24 hours time system. As an example for the screen shown above any hall or cabin call register can be active between from 8:30am to 12:30pm if it is selected as PE1.

2-E) P5-MAINTENANCE TIME

You can see or set next maintenance date by using P5 in menu M20. In this section, you see current settings of the next maintenance date.

ACS Series

```
NEXT MAINTENANCE
31/12/2019
```

ACH and ACT Series

```
NEXT MAINTENANCE
31/12/2019
```

If you press any key in this screen then you will come to the maintenance date editing screen.

ACS Series

```
NEXT MAINTENANCE
DAY..: ?000031
MONTH: ?000012
YEAR..: ?002019
```

ACH and ACT Series

```
NEXT MAINTENANCE
DAY..: ?000031
```

You can change maintenance date in this screen. When the real date exceeds maintenance date, then the lift pass to out of service mode. You can also see "MAINT" text in the main screen when maintenance date is exceeded.

2-F) P6-OUTPUT DEFINITIONS

In AC Series, there are up to 33 programmable outputs plus 1 output on additional ERS system. Select the output number from output screen menu and press (ENT) button to change. Then choose which function is linked to this output from the second screen and complete the output definition with (ENT). The summary of these outputs are as follows:

NO	CODE	PLACE	CONTACT V/I	CONTACT TYPE	EXPLANATION
1	S1	ACS/ACH/ACT	220V/10A	Normally Open Common	Freely programmable in all lift types.
2	S2	ACS/ACH ACT	220V/10A Transistor	Normally Open Common	Freely programmable in all lift types.
3	S3	ACS	220V/10A	Normally Open Common	Freely programmable.
4	S4	ACS/ACH/ACT	220V/10A	Normally Open Common	Freely programmable in all lift types.
5	O1	OUT	220V/5A	Normally Open	O1, O2, O3 relays have same common COM and O4 has common C4 on OUT board.
6	O2	OUT	220V/5A	Normally Open	
7	O3	OUT	220V/5A	Normally Open	
8	O4	OUT	220V/5A	Normally Open	
9	O5	EOR	220V/5A	Normally Open	O1, O2, O3 and O4 relays are all have the same common (C1) on EOR board.
10	O6	EOR	220V/5A	Normally Open	
11	O7	EOR	220V/5A	Normally Open	
12	O8	EOR	220V/5A	Normally Open	
13	O9	EOR	220V/5A	Normally Open	O5, O6, O7 and O8 relays are all have the same common (C2) on EOR board.
14	OA	EOR	220V/5A	Normally Open	
15	OB	EOR	220V/5A	Normally Open	
16	OC	EOR	220V/5A	Normally Open	
17	R1	SCC/ACC	220V/5A	Normally Open	Freely programmable in all lift types.
18	R2	ACC	220V/5A	Normally Open	Freely programmable in all lift types.
19	R3	ACC	220V/5A	Normally Open	Freely programmable in all lift types.
20	R4	ACC (OUT)	220V/5A	Normally Open	O1, O2, O3 relays have same common COM and O4 has common C4 on OUT board.
21	R5	ACC (OUT)	220V/5A	Normally Open	
22	R6	ACC (OUT)	220V/5A	Normally Open	
23	R7	ACC (OUT)	220V/5A	Normally Open	
24	E1	SCC/ACC (EOR)	220V/5A	Normally Open	O1, O2, O3 and O4 relays are all have the same common (C1) on EOR board.
25	E2	SCC/ACC (EOR)	220V/5A	Normally Open	
26	E3	SCC/ACC (EOR)	220V/5A	Normally Open	
27	E4	SCC/ACC (EOR)	220V/5A	Normally Open	
28	E5	SCC/ACC (EOR)	220V/5A	Normally Open	O5, O6, O7 and O8 relays are all have the same common (C2) on EOR board.
29	E6	SCC/ACC (EOR)	220V/5A	Normally Open	
30	E7	SCC/ACC (EOR)	220V/5A	Normally Open	
31	E8	SCC/ACC (EOR)	220V/5A	Normally Open	
32	EKS S1	ERS(EKS)	220V/5A	Normally Open	Freely programmable in all lift types.
33	KK	ACS/ACH/ACT	220V/10A	Normally Open Common	Freely programmable in all lift types when door relays on mainboard is not using. Common terminal is KO.
34	KA	ACS/ACH/ACT	220V/5A	Normally Open Common	Freely programmable in all lift types when door relays on mainboard is not using. Common terminal is KO.

CODE	SELECTED CASE	EXPLANATION
1	STOP CLOSED	Stop circuit is closed (Terminal 120 is on)
2	STOP OPEN	Stop circuit is open (Terminal 120 is off)
3	INSPECTION	System is in Inspection mode (Terminal 869 is on)
4	NORMAL OPERATION	System is in normal mode (Terminal 869 is off)
5	FAULT OCCURANCE	There is an error
6	NO FAULT	There is no error, system works normal
7	SLOW MOTION	The car is moving at slow speed
8	NO SLOW MOTION	The car is not moving at slow speed
9	NO MOTION	The car is not moving
10	MOTION	The car is moving at any speed
11	FAST MOTION	The car is moving at fast speed
12	FAST / HIGH MOTION	The car is moving at fast or high speed
13	DOOR LOCK CLOSED	Door lock circuit is closed. (Terminal 140 is on)
14	DOOR LOCK OPEN	Door lock circuit is open. (Terminal 140 is off)
15	AT FLOOR LEVEL	The cabin is at floor level
16	AT FLOOR LEVEL NO MOTION	The car is staying in rest and the cabin is at floor level
17	DIRECTION UP	Direction is up
18	DIRECTION DOWN	Direction is down
19	BUSY ON	Busy
20	DEFINED ID	If the access control or the priority system are activated and a defined key is swiped, it activates.
21	GMV 2CH/S	GMV 3010 2CH/S type hydraulic valve out.
22	LEVELING UP	Upwards releveling
23	LEVELING MOTION	The system is in releveling motion
24	PARK TIME	Waiting for park period
25	MOTION+BRAKE	The system is in motion or in braking
26	RETIRING CAM	Retiring cam. Door contacts are closed and there is motion
27	MOTION+BRAKE(INS)	The system is in motion or in braking
28	HIGH SPEED	The car is moving at 3 rd Speed (High)
29	PAWL DEVICE	Pawl device output
30	EMERGENCY LANDING VALVE	When the system is in ERS (Resque System) mode, the emergency landing valve activates.
31	NO CALLS	There is no call registered
32	ZERO SPEED	Zero speed output for VVVF drives. (Jog)
33	JOG SPEED	The system is in inspection mode and in motion
34	M0 SIMULATOR	Simulator outputs
35	MK SIMULATOR	
36	817 SIMULATOR	
37	HYDRAULIC DOWN	Up motion in hydraulic lift
38	HYDRAULIC UP	Down motion in hydraulic lift
39	DEVICE RESET	Device reset signal on device error
40...44	M0...M4	Gray code outputs
45	CLOSE 2 nd DOOR	Close door signal for door 2
46	OPEN 2 nd DOOR	Open door signal for door 2
47	GONG	Gong
48	LEVELING	Leveling
49	FIRE	Fire signal is active.(FR1 or FR2)
50	DOOR BRIDGING	Door pre-opening
51	DOOR LOCK+BRAKE	Door lock + brake
52	FAST DELAY	Fast Delay

CODE	SELECTED CASE	EXPLANATION
53	DOWN SERVICE ARROW	Down service arrow
54	UP SERVICE ARROW	Up service arrow
55	MAX. START COUNTER	Maximum number of start exceeded. P0- Maximum number of start exceeded is higher than parameter.
56	ML OUTPUT	ML output (Lift is in slow speed and ML input is active) ML1 and ML2 inputs are active at the same time.
57	HYDRAULIC MOTION	Hydraulic motion (37+38)
58	ALARM FILTER	Emergency phone alarm filter
59	DSV-A3 VALVE	DSV-A3 Valve
60	FIRE DOOR ALARM	Door close command output in fire
61	NO FLOOR LEVEL 140-	Door lock failure out of floor level
62	PRIORITY CALL	Priority call
63	OUT OF SERVICE	Out of service signal
64	OVERLOAD	Overload (804 input is active)
65	OVERLOAD SIGNAL	Overload signal (Output Signal 35 is active)
66	SLOW OR STOP	Slow speed or stop
67	POWER LINE OK	Power line is OK
68	POWER LINE FAILURE	Failure on power line
69	ERS is PASSIVE	ERS is not active
70	ERS is WORKING	ERS is active
71	UPS ERS	UPS ERS is active
72	ERS FKK	FKK in ERS mode
73	FIRE	Fire signal
74	DOOR SIDE A	Door A is active
75	DOOR SIDE B	Door B is active
76	COUNTER M0	Counter M0 signal
77	NEXT DIRECTION DOWN	Next direction is down
78	NEXT DIRECTION UP	Next direction is up
79	NOT BUSY	System is not busy
80	FAN	Fan is active
81	SHORT FLOOR BOTTOM	If bottom floor is shorter than the other floors and when the target is bottom floor, this output activated (1 sec) one floor before reaching bottom floor. (Set 81 to [B07])
82	SHORT FLOOR TOP	If top floor is shorter than the other floors and when the target is top floor, this output activated (1 sec) one floor before reaching top floor. (Set 82 to [B07])
83	SPEED GOVERNOR COIL	Speed governor coil is activated
84	HALL CALL SIGNAL	There is a call in system. (Only when WM2 is active (Parallel))
85	DOWN IN FIRE	Lift is moving downwards direction in fire
86	UP IN FIRE	Lift is moving upwards direction in fire
87	HIGH TEMPERATURE	This output activated if temperature is more than [B46]
88	DOOR INHIBITED	This output activated if the door is not close among [C40]
89	BLOCKED	System is blocked as a result of an error.
90	ULTRA SPEED	Ultra speed is active
91...95	B0...B4 BINARY CODES	Binary code outputs
96	LOADING	Loading period (C32) is activated by LDB input.
97	SWITCH OFF UPS	Switch UPS off after completing rescue operation.
98	M5 GRAY CODE	Gray Code M5 Out
99	B5 BINARY CODE	Binary Code B5 Out
100+i	CAR STAYING AT FLOOR	The car is staying in rest at 'i' th floor
200+i	CAR IS AT FLOOR	The car is in 'i' th floor

After the procedure described above, the defined output relay will be activated according the event you selected. If the state of lift matches the one you selected than the output relay is ON otherwise it is OFF.

To program these outputs, firstly select P6 in menu M20 and see the following screen:

ACS Series

```
S1:026 LIRPOMP
S2:000 FREE
S3:000 FREE
S4:000 FREE
```

ACH and ACT Series

```
S1:26 LIRPOMP
S2:0 FREE
```

Set Output No at row 2 and see the related output at bottom row. As an example, let us set S1 output as error indicator. Choose Output No =1.

ACS Series

```
TERMINAL: S1
BOARD : (ACS)
?000026
CAM
```

ACH and ACT Series

```
CAM
S1: ?000026
```

Then set output code as 5 and push ENT to save the changes. From now on, S1 relay will be activated in case of an error.

ACS Series

```
TERMINAL: S1
BOARD : (ACS)
?000005
FAULT OCCURANCE
```

ACH and ACT Series

```
FAULT OCCURANCE
S1: ?000005
```

2-G) P7-INPUT DEFINITIONS

The details of this section are explained in 1-C and 1-D sections.

2-H) P8-DATE & TIME

The time and date of the system can be set in this section.

ACS Series

```
YEAR.....:2017 M26
MONTH....:07
DAY.....:11
HOUR....:17
```

ACH and ACT Series

```
YEAR.....:2017
>MONTH....:07
```

You can edit any item in this screen after selecting line by using (↑) and (↓) keys and then pressing (ENT) key.

ACS Series

```
SET DATE AND TIME  
MONTH...  
?000007
```

ACH and ACT Series

```
MONTH...  
?000007
```

You can change the data by using (↑) and (↓) keys. In order to pass from column to column, use (←) and (→) keys. After complete editing, press (ENT) key to save the new data. In the same manner, you can edit year, month, day, hour and minute.

2-I) P9-UTILITIES

This section contains some non-standard procedures utilities which may help you to configure your system.

ACS Series

```
>R1-DISPLAYS      M28  
R2-FACTORY SETTINGS  
R3-SET INPUTS  
R4-MODEM SETTINGS
```

ACH and ACT Series

```
>R1-DISPLAYS  
R2-FACTORY SETT
```

2-I-1) R1-DISPLAY UTILITIES

In this utilities section the following screen is waiting for an input:

ACS Series

```
BASE FLOOR NO?000002
```

ACH and ACT Series

```
BASE FLOOR NO...:  
?000002
```

You can change the data by using (↑) and (↓) keys between 0 and maximum floor number. If you specify which floor is the entrance floor of the building then this utility sets the digital display of the entrance floor (base floor) as 0. All floors above this floor are numbered starting from 1 and incremented by 1 at every floor. All floors below 0 (base floor) are numbered starting from -1 and decremented by 1 at every floor. If you have a regular display order in your system but few exceptions, first use the utility explained above and change the data for exceptional floors one by one.

2-I-2) R2-FACTORY SETTINGS

If you want to set all parameters to factory settings values then you can use this section. It clears all the parameters entered by the user and set them to factory defaults.

2-I-3) R3-SET ALL INPUTS

Setting all of the inputs according to the system (parallel or serial) used is explained in section 1-D.

2-I-4) R4-MODEM SETTINGS

ACS Series

```
>X1-TEL #1-ERROR
X2-TEL #2-ALARM
X3-SETTING 1
X4-SETTING 2
```

ACH and ACT Series

```
>X1-TEL #1-ERROR
X2-TEL #2-ALARM
```

- X1) Phone number will be used by the GSM modem in case of an error
- X2) Phone number will be used by the GSM modem in case of an alarm
- X3) Modem initialization string 1
- X4) Modem initialization string 2

2-I-5) R5-RESET PULSES

ACS Series

```
ALL ENCODER
PULSE WILL CLEAR

ENT-OK
```

ACH and ACT Series

```
ALL ENCODER
PULSE WILL CLEAR
```

You can enter this section if you are using incremental or absolute encoders as floor detector. When you see the screen as above then pressing (ENT) will make all encoder pulse records as 0.

2-I-6) R6-OTHER UTILITIES (Do NOT Use)

This menu is designed for authorized technical persons. There is no function for user. It may cause undesired results to enter anything to this menu. If you enter this menu by mistake, exit by ESC key.

2-I-7) R7-SET PASSWORD

You can change your password from this utility. When enter this menu, system asks current password.

ACS Series

```
CURRENT PASS ?000000_
```

(ENT)

```
CURRENT PASS ?002345
NEW PASSWORD ?003200
Confirm New Password
ENT-SAVE
```

ACH and ACT Series

```
PASSWORD ?000000_
```

(ENT)

```
PASSWORD ?002345
NEW PASS.?003200
```

(ENT)

```
Confirm New Pass
ENT-SAVE
```

If you enter password correctly then system permits you to change system password between 0 and 32000. Here if you again push ENT new password will be saved. However, you can cancel changes by pushing ESC button.

2-I-8) R8-COUNTER

Counter value that lift able to make until next maintenance. You can see current counter value in state screen (if you hold ESC button pressed on main screen). Counter can be set between 1 and 99999. It will be passive when you set this parameter as 0. When lift counter exceed this parameter value, system will BLOCKED. To activate system again, increase this parameter value or set it passive by 0.

ACS Series

```
CLEAR START COUNTER
(↑) -CONTINUE
```

ACH and ACT Series

```
CLEAR START COUN
(↑) -CONTINUE
```

2-I-9) R9-ACCESS CONTROL

Access control utility permits only the users with appropriate allowance to use the lift, in other words, it restricts any person who has not allowed to use the lift for a specific floor or time interval. For this purpose, each lift users should have a RFID card or i-Button key with a unique user ID.

In this section, it will be explained how to register a new ID to the system as well as how to change its allowance details. Access control system is active only when the parameter [B31] has a value greater than '0'. As you enter to this section, you will be faced with the following menu.

ACS Series

```
>Y1-ID LIST
Y2-ADD NEW ID
Y3-CLEAR ID
Y4-CLEAR ALL IDS
```

ACH and ACT Series

```
>Y1-ID LIST
Y2-ADD NEW ID
```

i) ID LIST

For editing registered ID settings, you can use "Y1-ID LIST". When this section has been selected then registered ID list will be shown on the screen.

ACS Series

```
>0A6578BF/FFFFFFFF/1
0A632B16/00000008/2
0A65678C/00000024/1
```

ACH and ACT Series

```
>0A6578BF/FFFF/1
0A632B16/0008/2
```

As you can see above each line shows one ID-code which contains three parts.

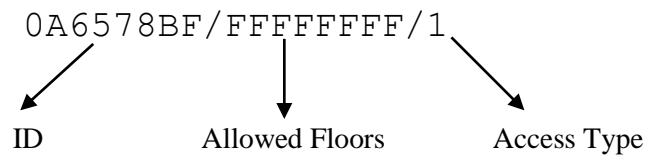

The left part "0A6578BF" stores the unique ID-code for the users. The middle part "FFFFFFF" holds the information of the floors permitted to go for the users. Each floor has been represented by a bit in this information, where '1' means allowance and '0' means restriction. The information on the right side specifies the status of the allowance. The detailed explanations of them will be given below.

You can move the arrow at the left side of the ID LIST by (↑) and (↓) keys. Select the line you want to edit then press ENT.

ACS Series

```

ID NO : 0A6578BF
SELECT OPERATION
?000001
ALL FLOORS ALLOWED
    
```

ACH and ACT Series

```

>0A6578BF/FFFF/1
  0A632B16/0008/2
    
```

The table below shows the operations you can select and their explanation and operation codes.

1	All Floors Allowed	To allow all floors, choose 1 with (↑) and (↓) keys and press ENT. (Floors = FFFFFFFF)	
2	No Floors Allowed	To restrict all floors, choose 2 with (↑) and (↓) keys and press ENT. (Floors = 00000000)	
3	Edit Allowance	0 – No Access	No access to call register
		1 – Full Access	Full access to permitted floors call registers
		2 – Accessible in PE1	Access to permitted floors call register only in PE1 period (K8-Call Register Periods)
		3 – Accessible in PE2	Access to permitted floors call register only in PE2 period (K8-Call Register Periods)
		4 – Priority Key	Key is a priority key.
4	Allow One Floor	Choose floor number you want to allow with (↑) and (↓) keys and press ENT (It is 32-bit binary number shown in hexadecimal format. Each bit represents one floor) For stops 3, 5, 10, 16, 23, 30: Floors : 40810428 (01000000100000010000010000101000b)	
5	Restrict One Floor	Choose floor number you want to restrict with (↑) and (↓) keys and press ENT (It is 32-bit binary number shown in hexadecimal format. Each bit represents one floor) For stops 0, 7, 12, 19, 25, 29: Floors : 22081081 (00100010000010000001000010000001b)	

ii) FORMATS

When you want to add a new card or key to the system then you must assign it to a format. A format holds the informations besides ID-code, namely allowed floors and status. There are 15 formats in the system. Therefore we recommend you to evaluate your formats before starting to add keys or cards. The idea behind formats is to group users with similar allowance criteria. When you first save the allowance

details in a format, then you can add a number keys or card with this format and lots of details will be saved automatically. You do not to edit the specifications for each new user separately. To edit formats, proceed to the “Y5-FORMATS” line in R9 menu and press ENT key. You will see the following screen:

ACS Series

```
>01:00000000/1
 02:00000000/1
 03:00000000/1
 04:00000000/1
```

ACH and ACT Series

```
>01:00000000/1
 02:00000000/1
```

There are 15 formats in the system. You can see all formats with the number 0 to 14 by moving the (↑) and (↓) keys on the screen. Select the one you want to edit and then press ENT. You can edit a format similarly to the editing of an ID explained in the previous item. The only difference is that the information edited belong to a format not to an ID-code. Therefore you will select a format number rather than an ID-code to start.

All formats have the information “all floors are restricted” as default. You can add the floors you want to allow by using operation '4', namely “ALLOW ONE FLOOR”, one by one to evaluate your format. Similarly you can edit the status in the format.

The reason for saving more than one format is that you can split the users with similar access rights into groups and assign a different format to each group. So in adding new cards or keys to the system, first select format and then register all the cars in this group.

iii) ACTIVE FORMAT

In this section you can select the default format which will be active when you enter into the “ADD NEW ID” operation.

iv) ADD NEW ID

To add a new ID, select Y2-ADD NEW ID line with (↑) and (↓) keys and press (ENT) button. On the new screen, system will wait you to put a key or card to any station to read.

ACS Series

```
>ANY STATION
 1:00000000/1
```

ACH and ACT Series

```
>ANY STATION
 1:00000000/1
```

You can see on the screen the active format. It is '1' on the screen above. You can change the active format by (↑) and (↓) keys in 0-14 range. The system will wait from you to put a key or card to the reader. When you put the card or key then its ID-code will be shown on the screen.

ACS Series

0A6578BF REGISTERED

ACH and ACT Series

0A6578BF REGISTERED

The new registered ID will be saved with the allowance and status specifications of the current format. However you can change its specifications as explained above in "ID LIST" section anytime you want. When registering a number of new keys or cards to the system with the same allowance and status specifications, you can go on adding them without changing the current active format.

v) CLEAR ID

You can use this section in order to clear any ID-code from the system. In order to do this, select the ID-code by (↑) and (↓) keys. Then press ENT key when the arrow on the screen shows the ID-code you want to clear. Then you will be prompted to press down key to continue. Press (↓) key to clear the ID-code and complete the job.

vi) CLEAR ALL ID-codes

In this section you can clear all keys registered in the system in one operation. You will be prompted with the following screen after selecting this section. Press (↓) key to clear all ID-codes in the system and complete the job. Please take care to carry on this operation!

vii) FREE FLOOR

When using an access control system there may be a request to leave some floor freely accessible, for example entrance floor. In this section you can program free floor(s).

When you select this section an operation code will be requested from you. The operations you can carry on and codes to set free floor(s) are listed below:

1	All Floors Allowed	In order to allow all floors, select '1' as operation code by (↑) and (↓) keys and press ENT key.
2	No Floors Allowed	In order to restrict all floors, select '2' as operation code by (↑) and (↓) keys and press ENT key.
4	Allow One Floor	Choose the floor number you want to assign as free floor by (↑) and (↓) keys and press ENT key.
5	Restrict One Floor	Choose the floor number you want to stop being free floor by (↑) and (↓) keys and press ENT key.

2-I-10) RA-ENCODER SETUP

After completing all installation (817, 818, encoder, encoder rope, MK switch, magnets), connection and parameters settings, start auto-learning process. In normal mode enter M2-PARAMETERS>P9-UTILITIES>RA>ENCODER SETUP menu. Press (↑) button to start auto-learning process.

ACS Series

```
ENC SHAFT LEARNING
(↑) -START
```

(↑)

```
ENC SHAFT LEARNING
      1030
F:01  FLR:00  100
0
```

```
ENC SHAFT LEARNING
OK
ENT-SAVE
```

ACH and ACT Series

```
ENC SHAFT LEARN
(↑) -START
```

(↑)

```
F:01  FLR:00  1000
0      1030
```

```
OK
ENT-SAVE
```

Firstly, car comes to bottom floor then it goes up in high speed to top floor to read all floor MK magnets and calculating floor distances. Then it goes to bottom and moves up again. During this up travel, it moves slowly at floor levels and measures length of strip magnets on MK line.

To take average of magnet lengths, system calculates exact floor levels. So when car reaches to top floor, process finishes. An approval message is shown on LCD screen.

By pushing (ENT) button all pulse values are stored in permanent memory. By pushing (ENT) button again, lift gets a call for bottom floor and moves.

During auto-learning process, system assigns K6-FLOOR PULSES and K7-GENERAL PULSE>MK LENGTH UP and DOWN parameters automatically. Bottom floor pulse value is assigned as 1000. All pulse values can be changed manually for fine-tuning. MK LENGTH values will be higher than actual length. This is because magnetic field of magnet is larger than its actual size. For detailed information, please look at “SHAFT POSITIONING SYSTEM WITH INCREMENTAL ENCODER INSTALLATION MANUAL”.

2-I-11) RB-ENCODER DIRECTION (Absolute Encoder)

You change encoder pulse direction from this menu.

2-J) P0-MAX START

This menu limits max travel count for maintenance purposes.

2-K) PA-LIFT NUMBER

(Not used)

CHAPTER 3: ERROR LOG AND ERROR CODES

In AC Series Control Systems, all determined errors are reported at runtime on main screen and stored in permanent memory. Error storing capacity of system is limited to 250. If an error occurs when there are 250 errors stored in memory, then oldest error is cleared and the new one is stored. You can see last 250 stored errors anytime by using LCD screen or from computer connection. Here we will see how to see error list reports by using keypad and LCD.

On main menu, enter M3-ERROR LOG sub-menu.

ACS Series

```
M1-VARIABLES      M00
M2-PAREMETERS
>M3-ERROR LOG
M4-LANGUAGE/DiL
```

ACH and ACT Series

```
>M3-ERROR LOG
M4-LANGUAGE/DiL
```

And then you see the list of stored error logs.

ACS Series

```
013) 18-F11 22.12.16
014) 03-F08 12.11.16
015) 06-F07 08.10.16
>016) 02-F03 13.09.16
```

ACH and ACT Series

```
015) 06-FLR:7
>016) 02-FLR:3
```

Error logs are sorted by date&time property. In this screen, you can only see floor, error date, time and error code. If you want to see more detailed report, select an error by using arrow keys and push (ENT) button.

ACS Series

```
/OLD ERROR REP./#2
13.09.2016 - 17:53
FLR:3 FAST ↑
DOOR CONT.ARE OPEN
```

ACH and ACT Series

```
DOOR CONT OPEN
02-FLR:3 FAST ↑

DOOR CONT OPEN
13.09.2016-17:53
```

In this screen, you see error date&time, floor, speed and direction of car (when error occurred) and explanation of error. Enter Code:399 (M5-SERVICES) to clear all error list.

Till the board records any new error and the lift is moving you can not enter the menu M3>Error Log and Codes.

AC SERIES ERROR CODES		
CODE	ERROR	EXPLANATION
1	Stop Circuit Is Open	Stop circuit-120 (Speed regulator, parachute contact, stop buttons...) is cut during motion.
2	Door Cont. Are Open	Door Contact circuit-130 is cut during motion.
3	Door Locks Are Open	Door Lock circuit-140 is cut during motion.
4	Bottom Limit Is Open	Down limit signal (817) is cut during down motion. (Except bottom floor)
5	Top Limit Is Open	Up limit signal (818) is cut during up motion. (Except top floor)
6	Pass Time Overflow	At fast speed, system could not get new floor data during the period defined at [C08]. At slow speed, system could not get Stopper (MK) signal during the period defined at [C09].
7	Door Cannot Open	After transmitting door open command, Door Lock (130) or Door Contact signals have not cut during the period defined at [C04].
8	Lock Wait Overflow	After transmitting door close command, Door Lock (130) or Door Contact signals could not read during the period defined at [C05].
9	High Limits Are Open	Both up and down high speed limits (817 and 818) are open.
10	Floor Info Error	Error in floor information.
11	Counter Error	Inconsequence in displays and limit signals at top/bottom floor.
12	Encoder Direction Error	Replace ENA and ENB connection to each other.
13	No Encoder Signal	Check electrical connections and rope contact of encoder.
15	Park Floor Definition Is Wrong	Defined park floor [B04] is more than maximum number of stops [A01].
16	Fire Floor Definition Is Wrong	Defined fire floor [B05] is more than maximum number of stops [A01].
17	Traffic System Error	Error about PI configuration board related to traffic system.
18	No Car Communication	System cannot communicate with car unit in serial communication mode.
19	No Landing Communication	System cannot communicate with floor unit(s) in serial communication mode.
20	PTC/Thermistor Failure	System cannot get signal from thermistor.
21	Fast Limits Are Open	System uses 3 rd speed. But there is no signal at mid-speed limit inputs (HU, HD).
25	Encoder Data Error	Pulse data on K6>FLOOR PULSES menu is missed or faulty.
26	Machine Room Temperature	THR input is open circuit. Check thermostat connections and settings.
27	Driver Error	System gets error signal from hydraulic or speed control (inverter) unit.
28	Releveling Error	Although car is out of safety zone (MK1, MK2 closed), releveling command is received from shaft.
29	Contactor Failure	Although there are no contactors activated and the door is open, there is no signal in CNT terminal.
30	Phase Failure	Failure in phases.
31	Phase Sequence Error	Error in phase sequence.
32	External FKK Error	Signal received from external FKK input.
33	ML2 Open At Floor	Check the magnet locations and ML2 shalter in releveling zone.
34	ML2 Short Circuit	Check the MK, MKD, MKU shalters and magnet locations in releveling zone during door bridging is active.
35	L1/R Phase Failure	L1/R phase is cut.
36	L2/S Phase Failure	L2/S phase is cut.
37	L3/T Phase Failure	L3/T phase is cut.
38	No Motion In System	No motion detected in defined time [C21]. If RUN input is not used, set [C21] parameter as 0.
39	Group No Failure	There are more than one member in the group with the same group number specified [A13].

CODE	ERROR	EXPLANATION
40	EMD Failure	When the system is in ERS mode, no communication with EMD board.
41	Leveling Period Exceeds	Leveling process took longer time than the period specified in parameter [C23].
42	CAN-0 Line Error	Serial communication line of car and landing units reported LINE ERROR.
43	CAN-0 Bus Error	Serial communication line of car and landing units reported BUS ERROR.
44	Maximum Motor Time	Maximum motor movement time [C28] is exceeded.
45	Bridging Error	SLB (or ACH) board cannot bridge safety line.
46	ERS TI Error	In emergency rescue operation, transformer inverter is not running.
47	ERS MI Error	In emergency rescue operation, motor inverter is not running.
48	Low Battery	In emergency rescue operation, the battery voltage is too low.
49	ERS Door Not Open	In emergency rescue operation the door cannot be opened in time period stored in timer parameter [C29].
50	ERS Door Not Closed	In emergency rescue operation the door cannot be closed.
51	ERS Maximum Current	In emergency rescue operation the motor current in emergency rescue operation is higher than the current value stored in parameter [B30].
52	ERS Period Exceeds	Emergency rescue operation period exceeded the period stored in timer parameter [C25].
53	ML1 Open At Floor	Check the magnet locations and ML1 shalter in releveing zone.
54	ML1 Short Circuit	Check the MK, MKD, MKU shalters and magnet locations in releveing zone during door bridging is active.
55	Hydraulic Upper Stop	Hydraulic lift top stop limit point is passed and stop line is opened.
56	24V Not Present	Signal circuit supply is cut. (Check 100/1000)
57	Call Button Error	Hall/Cabin call button is not released.
58	Earthquake	Earthquake signal received from input.
59	Start Prohibited	GMV NGV-A3 Type Hydraulic. RDY and RUN inputs are both OFF.
60	Start Prohibited	GMV NGV-A3 Type Hydraulic. RDY and RUN inputs are both ON.
61	NGV Signal Error	RDY,RUN inputs states are not change on START. (RDY=0,RUN=1)
62	NGV Signal Error	RDY,RUN inputs states are not change on STOP. (RDY=1,RUN=0)
63	External UCM Error	External UCM error signal received from input.
64	Brake Not Closed	Although brake coil is not energized, no signal received from brake feedback contact. Check BR1, BR2 terminals.
65	Brake Not Opened	Although brake coil is energized, signal received from brake feedback contact. Check BR1, BR2 terminals.
66	KSG Contact Failure	Although KSG contactor is not energized, SGC input signal is active.
67	KSG Contact Failure	Although KSG contactor is energized, SGC input signal is not active.
68	Security Valve Fault	Error in security valve.
69	Down Valve Fault	Error in down valve.
70	Overspeed Governor Contact Failure	While lift is moving, although overspeed governor coil is energized, SGO, SGC input signals are wrong. (They must be SGO=0, SGC=1).
71	Undefined Region	In encoder application, high speed limit inputs are inconsistent
72	UCM Fault	Unintended Car Movement UCM detected.
73	SGO Contact Failure	Although OSG A3 coil is not energized, SGO input signal is not active.
74	SGO Contact Failure	Although OSG A3 coil is energized, SGO input signal is active.
75	iValve Failure	An error signal is received on RDY input from iValve unit +SMA output.
76	End Shalters Failed	Top and bottom end shalters (917,918) are both open-circuit simultaneously. ([B61]=1)
77	HD/HU Error	System gives this error if HD input is active when 817/KSR1 input is passive or if HU input is active when 818/KSR2 input is passive.

CODE	ERROR	EXPLANATION
78	Encoder Communication Failure	When the encoder can not communicate with the system, this failure is shown. (For CAN-Bus Encoder)
79	Encoder Learning Failure	When the encoder can not complete the learning process, this failure is shown.

CHAPTER 4: VARIABLES AND LANGUAGE

On main menu you see M1-VARIABLES at first line.

ACS Series

```
>M1-VARIABLES      M00
M2-PARAMETERS
M3-ERROR LOG
M4-LANGUAGE/DiL
```

ACH and ACT Series

```
>M1-VARIABLES
M2-PARAMETERS
```

This menu is designed to observe all system variables, timers and inputs. This is an observation tool for technical persons to investigate system with details. There is no danger for users to enter this menu and observe variables. However, details of this menu will not be explained in this manual.

Another item in main menu is M4-LANGUAGE/DiL.

ACS Series

```
M1-VARIABLES      M00
M2-PARAMETERS
M3-ERROR LOG
>M4-LANGUAGE/DiL
```

ACH and ACT Series

```
M3-ERROR LOG
>M4-LANGUAGE/DiL
```

This is shortcut to menu [B11] that is explained above. You can change menu language from this menu. When this manual is prepared, supported languages are Turkish, English, German, French, Russian, Spanish and Greek. New languages will be supported near future.

The last item in main menu is M5-SERVICES. This menu is the shortcut of the R6 menu explained before

399 code : All errors can be cleaned

101 code : Parameters of the board can be set to the default settings. (Do not use is until necessary.)

ACS Series

```
M2-PAREMETERS      M00
M3-ERROR LOG
M4-LANGUAGE/DiL
>M5-SERVICES
```

ACH and ACT Series

```
M4-LANGUAGE/DiL
>M5-SERVICES
```

This is also a shortcut to R6-OTHER UTILITIES menu. As explained above, this menu is only for authorized technical persons. There is no function for user. It may cause undesired results to enter anything to this menu. If you enter this menu by mistake, push ESC to exit.

CHAPTER 5: UCM SERVICE

M6-UCM SERVICE menu is used for EN 81-1/2+ A3 norm related functions.

5-A) U1-CLEAR ERROR

This menu is used to clear UCM Errors (Error 64 and Error 72) that caused the system to be blocked. Before clearing the error and removing the blockage, the reason of error must be detected and removed. Error clearing must be performed by only competent person.

5-B) U2-UCM TEST (*SLB board required for ACT/ACS Series*)

This utility is active with systems that are conformity with EN81-1/2+A3 standard ([A17]=1 and above). It begins to UCM test.

5-C) U3-TEST TIME

This parameter defines the start date and time for periodic Automatic Test Procedure according to EN 81-1/2+A3 norm. It is active only when parameter [B59]=2 (Daily Check) and RTC is installed. After completing autotest, the test date is automatically assigned to the next day.

5-D) U4-TEST START

This parameter defines the number of start period of Automatic Test Procedure according to EN81-1/2+A3 norm. When the number of start value reaches the multiples of this period, Automatic test is started. It is active only when parameter [B59]=1 (Start Count) and can be set between 2 and 1500.

5-E) U5 -TEST COUNTER

Actual number of starts passing after the last Autotest is counted in this parameter for monitoring purposes.

5-F) U6 -VALVE TEST

This utility starts Valve Test procedure for Hydraulic systems.

5-G) UCM CONTROL OPERATION IN GEARED MACHINE SYSTEMS

In AC Series Electric Lift Controllers with Asynchronous (Geared) machines, UCM detection and control is performed by using special Overspeed Governors designed and certified for this purpose.

The OSG has an extra mechanism that is activated/deactivated by a coil. When the coil is energized, it releases the wheel of OSG and allows it to rotate freely. And when the coil is released, it locks the wheel and prevents it from rotating. In this case if OSG wheel tries to rotate because of any car movement, then safety gear is activated and car is stopped. There are contacts on this mechanism showing the actual state.

One of these contacts is monitored by AC Controller and the other one is used to switch safety line.

There are 3 different methods to drive OSG coil defined by the parameter P2-AUX. PRMs>B58-SPEED.GOVN.COIL. These are:

1. ON IN MOTION
2. ALWAYS ON
3. ALWAYS ON+SLEEP

WARNING : Before setting [B58] as 2 or 3, it must be confirmed that the coil is 100% ED.

5-G-1) OPERATION OF THE SYSTEM WHEN [B58]=1 (ON IN MOTION)

When a movement is needed, AC controller first checks the safety circuit. If safety circuit is completed then AC controller activates KSG contactor via a programmable relay output. KSG contactor energizes OSG A3 coil and OSG wheel is released to rotate freely. After energizing KSG contactor, AC controller starts to monitor the state of the KSG contactor via SGC input and the state of the OSG A3 coil via SGO input on INPS board.

When KSG contactor is activated, NO contact is connected to SGC input on INPS board I2 terminal and it must be active too. If this input does not become active in 4 seconds, then AC controller will report Error 67: KSG CONT.FAILURE and reset KSG contactor and keep on monitoring. This procedure is repeated until SGC input is read properly or [B12]-MAX.ERROR REPEAT is exceeded. When number of repeating error exceeds B12 then system is blocked and no calls are accepted. This temporal blockage can be removed by passing to inspection mode or resetting the controller.

When KSG contactor is activated, one of its contacts activates OSG A3 coil. OSG A3 coil contact is connected to INPS board I1 input (SGO) and monitored by AC controller. If SGO input is not cut in 4 seconds after activation of KSG contactor then AC controller will report Error 74: SGO CONTACT FAILURE and reset KSG contactor and keep on monitoring. This procedure is repeated until SGC input is read properly or [B12]-MAX.ERROR REPEAT is exceeded. When number of repeating error exceeds [B12] then system is blocked and no calls are accepted. This temporal blockage can be removed by passing to inspection mode or resetting the controller.

After activating KSG contactor, if SGO input is passive and SGC input is active then AC Controller will start motion by activating direction and speed output relays. As motion is started, safety circuit return passes through OSG A3 coil contact (140-141) and energizes contactors. Activating contactors forms an alternative path (parallel to KSG NO contact) for OSG A3 coil AC supply line by using auxiliary contacts. Therefore even if KSG NO contact fails during motion, OSG A3 coil supply is not interrupted.

During motion, if SGO or SGC inputs change state then AC controller will report Error 70: SP.GOV.CONT.FAILURE and stop the motion without any delay. In this case KSG contactor is dropped with the delay defined in the timer [C42]-SP.GOV.STOP DELAY.

Similarly if car is stopped during motion because of any fault such that safety line cut, mains line fault or driver error, then AC controller will drop KSG contactor after [C42] period.

When car reaches the target and stops, KSG output drops after [C42] delay. As KSG contactor drops, OSG A3 coil drops too. AC controller starts to monitor SGO, SGC inputs.

If SGC input does not become passive in 4 seconds, then AC controller will report Error 66: KSG.CONT.FAILURE and lift is out of service until SGC input becomes passive.

If SGO input does not become active in 4 seconds, then AC controller will report Error 73: SGO.CONT.FAILURE and lift is out of service until SGC input becomes active. When number of repeating error exceeds [B12] then system is permanently blocked and no calls are accepted.

5-G-2) OPERATION OF THE SYSTEM WHEN [B58]=2 (ALWAYS ON)

When AC controller is energized it directly activates KSG contactor in both normal or inspection mode and monitors SGO and SGC inputs on INPS board. KSG contactor and OSG A3 coil are always energized unless a UCM occurs or safety line is opened out of door zone in normal mode. Monitoring and control procedures, error messages, controller responses are the same as when [B58]=1.

In order to check the functionality of OSG A3 Coil and KSG contactor, AC controller performs periodic tests by resetting KSG contactor. Test period is defined using P2-AUX. PARAMETERS>B59-UCM CHECK TYPE menu. Here STARTING COUNT or DAILY CONTROL options are available.

When DAILY CONTROL is selected, first test date and time is set by using M6-UCM SERVICES>U3-TEST TIME menu. When selected date and time is reached, controller looks for proper free time slot for test. When lift stays free for 150 seconds then TEST is started. After completing test, next day is assigned for test date and test time remains the same. So in this way everyday approximately at the same time test is performed.

When STARTING COUNT is selected, test period is entered to M6-UCM SERVICES>U4-TEST START menu as number of start. When number of start reaches the multiples of this number, controller looks for proper free time slot for test. When lift stays free for 150 seconds then TEST is started.

In test mode first KSG contactor is dropped. As KSG contactor drops, OSG A3 coil drops too. AC controller starts to monitor SGO, SGC inputs.

If SGC input does not become passive in 4 seconds, then AC controller will report Error 66: KSG.CONT.FAILURE and lift is out of service until SGC input becomes passive.

If SGO input does not become active in 4 seconds, then AC controller will report Error 73: SGO.CONT.FAILURE and lift is out of service until SGC input becomes active. When number of repeating error exceeds B12 then system is permanently blocked and no calls are accepted.

After completing test procedure successfully, KSG contactor is reenergized and system returns normal operation.

Beside these periodic tests, user can start test manually by using menu M6-UCM SERVICES > U2-UCM TEST.

NOTE 1: When [B59]=2 (Daily Control) is chosen, optional RTC board must be installed and parameter [B44] (DATE AND TIME) must be set as 1 (ACTIVATED) for ACT board.

NOTE 2: During TEST procedure AC Controller passes to Inspection mode and no calls are accepted.

5-G-3) OPERATION OF THE SYSTEM WHEN [B58]=3 (ALWAYS ON+SLEEP)

Operation of the system when [B58]=3 is nearly the same with the operation when [B58]=2. Only difference is that KSG contactor is dropped 150 sec. after lift becomes free (not busy). As KSG contactor drops, OSG A3 coil is released too. AC controller starts to monitor SGO, SGC inputs. Therefore there is no need for periodic tests.

Monitoring and control procedures, error messages, controller responses are the same as when [B58]=1 or 2.

5-G-4) UCM DETECTION AND CONTROL

a) STOPPING AT FLOOR LEVEL

After reaching the target floor, door is opened (safety line 140 circuit is open) and if [B58]=1 then AC Controller waits for [C42] period to release KSG contactor. When KSG is active, if any of door zone limit switches (ML1, ML2) is opened, then AC Controller accepts this as UCM and releases KSG contactor immediately without waiting [C42] period. AC controller reports Error 72:UCM FAULT and blocks itself permanently. Even if AC board is restarted, it will stay in blocked mode and error report will flash on the screen.

b) PREOPENING AND DOOR-OPEN RELEVELLING

Cabin is in door zone and moving in slow or leveling speed. Door is open and Door Bridging Board SLB bridges safety line. In this case, if any of door zone limit switches (ML1, ML2) is opened, then AC Controller accepts this as UCM. Door bridge is opened and motion is stopped and KSG contactor is released immediately. AC controller reports Error 72:UCM FAULT and blocks itself permanently. Even if AC board is restarted, it will stay in blocked mode and error report will flash on the screen.

During pre-opening or leveling/releveling if a fault occurs on SLB (Door Bridging) Board and SLB cannot bridge, then lift will be stopped and pass to Inspection mode. AC controller reports Error 45: BRIDGING ERROR and blocks itself permanently. Even if AC board is restarted, it will stay in blocked mode and error report will flash on the screen.

5-G-5) MANUEL UCM TEST PROCEDURES

To perform a proper and safe test, following conditions must be confirmed:

1. Door Bridging Board SLB is installed and connected properly.
2. Be sure that there is nobody inside cabin.
3. Lift must not be used during test.
4. Lift must be in normal mode (not inspection mode) during test.

NOTE: For a swing (manual) landing door (semi-automatic) system, before starting tests be sure that landing door of the floor where car stays, is fixed in open state.

a) **UPWARD UCM TEST**

Before start the test, bring the car one stop before top floor and be sure that cabin is empty. Enter M6-UCM SERVICES>U2-UCM TEST menu. Choose test speed as SLOW or FAST and then choose TEST DIRECTION as UP and push ENT.

At next screen S.GOV.UCM TEST message is displayed. Here push UP button to start test. At first AC Controller activates door open output and as door opens, safety circuit 140 signal is cut. AC controller bridges 140 signal via SLB board and then activates (if [B58]=1) KSG contactor. KSG contactor energizes UCM A3 coil. After checking the states of SGO, SGC inputs, AC Controller starts motion in selected speed. As the car moves upward with open-door, it goes out door zone and door zone limit ML2 is opened. Then AC Controller accepts this as UCM. Door bridge is opened and motion is stopped and KSG contactor is released immediately. AC controller reports Error 72:UCM FAULT and blocks itself permanently. Even if AC board is restarted, it will stay in blocked mode and error report will flash on the screen.

b) **DOWNWARD UCM TEST**

Before start the test, bring the car one stop before bottom floor and be sure that cabin is full loaded. Enter M6-UCM SERVICES>U2-UCM TEST menu. Choose test speed as SLOW or FAST and then choose TEST DIRECTION as DOWN and push ENT.

At next screen S.GOV.UCM TEST message is displayed. Here push UP button to start test. At first, AC Controller activates door open output and as door opens, safety circuit 140 signal is cut. AC controller bridges 140 signal via SLB board and then activates (if [B58]=1) KSG contactor. KSG contactor energizes UCM coil. After checking the states of SGO, SGC inputs, AC Controller starts motion in selected speed. As the car moves downward with open-door, it goes out door zone and door zone limit ML1 is opened. Then AC Controller accepts this as UCM. Door bridge is opened and motion is stopped and KSG contactor is released immediately. AC controller reports Error 72:UCM FAULT and blocks itself permanently. Even if AC board is restarted, it will stay in blocked mode and error report will flash on the screen.

c) **RESTORING FROM BLOCKED MODE**

Enter M6-UCM SERVICES>U1-UCM RESET menu and see CLEAR UCM ERROR message and push ENT button to confirm. This menu is functional only if the conditions causing UCM are fixed.

5-H) UCM CONTROL OPERATION IN GEARLESS MACHINE SYSTEMS

Normally close brake contacts on gearless machine brakes are connected to input terminals of INPS board on ACT, ACS mainboards.

AC main controller always checks BR1-BR2 brake contact state feedback signals. If any of these inputs cannot be read when there is no motion command by controller, then controller reports Error 64: BRAKE NOT CLOSED and blocks itself permanently. In this case no normal operation is possible.

Returning to the normal state is only possible by entering M6-UCM ERROR RESET menu and choosing YES. Restarting the board or passing to INSPECTION mode will not recover from BLOCKED state. Even if AC board is restarted, it will stay in blocked mode and error report will flash on the screen.

5-H-1) UCM DETECTION AND CONTROL

a) STOPPING AT FLOOR LEVEL

After reaching the target floor, door is opened (safety line 140 circuit is open). In this case, if any of door zone limit switches (ML1, ML2) is opened, then AC Controller accepts this as UCM, reports Error 72:UCM FAULT and blocks itself permanently. Even if AC board is restarted, it will stay in blocked mode and error report will flash on the screen.

b) PREOPENING AND DOOR-OPEN RELEVELLING

Cabin is in door zone and moving in slow or leveling speed. Door is open and Door Bridging Board SLB bridges safety line. In this case, if any of door zone limit switches (ML1, ML2) is opened, then AC Controller accepts this as UCM. Door bridge is opened and motion is stopped and KSG contactor is released immediately. AC controller reports Error 72:UCM FAULT and blocks itself permanently. Even if AC board is restarted, it will stay in blocked mode and error report will flash on the screen.

During pre-opening or leveling/releveling if a fault occurs on SLB (Door Bridging) Board and SLB cannot bridge, then lift will be stopped and pass to Inspection mode. AC controller reports Error 45: BRIDGING ERROR and blocks itself permanently. Even if AC board is restarted, it will stay in blocked mode and error report will flash on the screen.

***NOTE :** UCM conditions occurring in both cases during pre-opening and releveling with open-door are supposed to be the same.*

5-H-2) MANUEL UCM TEST PROCEDURE

To perform a proper and safe test, following conditions must be confirmed:

1. Door Bridging Board SLB is installed and connected properly.
2. Be sure that there is nobody inside cabin.
3. Lift must not be used during test.
4. Lift must be in normal mode (not inspection mode) during test.

NOTE: For a swing (manual) landing door (semi-automatic) system, before starting tests be sure that landing door of the floor where car stays is fixed in open state.

a) **UPWARD UCM TEST**

Before start the test, bring the car one stop before top floor and be sure that cabin is empty.

Enter M6-UCM SERVICES>U2-UCM TEST menu. Choose test speed as SLOW or FAST and then choose TEST DIRECTION as UP and push ENT.

At next screen S.GOV.UCM TEST message is displayed. Here push UP button to start test. At first AC Controller activates door open output and as door opens, safety circuit 140 signal is cut. AC controller bridges 140 signal on via SLB board and then activates (if [B58]=1) KSG contactor. KSG contactor energizes UCM coil. After checking the states of SGO, SGC inputs, AC Controller starts motion in selected speed. As the car moves upward with open-door, it goes out door zone and door zone limit ML2 is opened. Then AC Controller accepts this as UCM. Door bridge is opened and motion is stopped and KSG contactor is released immediately. AC controller reports Error 72:UCM FAULT and blocks itself permanently. Even if AC board is restarted, it will stay in blocked mode and error report will flash on the screen.

b) **DOWNWARD UCM TEST**

Before start the test, bring the car one stop before bottom floor and be sure that cabin is full loaded. Enter M6-UCM SERVICES>U2-UCM TEST menu. Choose test speed as SLOW or FAST and then choose TEST DIRECTION as DOWN and push ENT.

At next screen S.GOV.UCM TEST message is displayed. Here push UP button to start test. At first AC Controller activates door open output and as door opens safety circuit 140 signal is cut. AC controller bridges 140 signal on via SLB board and then activates (if [B58]=1) KSG contactor. KSG contactor energizes UCM coil. After checking the states of SGO, SGC inputs, AC Controller starts motion in selected speed. As the car moves downward with open-door, it goes out door zone and door zone limit ML1 is opened. Then AC Controller accepts this as UCM. Door bridge is opened and motion is stopped and KSG contactor is released immediately. AC controller reports Error 72:UCM FAULT and blocks itself permanently. Even if AC board is restarted, it will stay in blocked mode and error report will flash on the screen.

c) **RESTORING FROM BLOCKED MODE**

Enter M6-UCM SERVICES>U1-UCM RESET menu and see CLEAR UCM ERROR message and push ENT button to confirm. This menu is functional only if the conditions causing UCM are fixed.

5-I) UCM CONTROL OPERATION IN HYDRAULIC LIFTS

To fulfill the requirements of EN81-2 A3 norm, most of Hydraulic unit manufacturers added an extra safety valve running in down direction. This extra valve is located between piston and valve block serially and driven simultaneously with down direction valve.

ACH controller drives down direction valve and down direction A3 valve simultaneously (depending on hydraulic unit types) via different switches.

ACH also includes automatic (periodic) test function for down A3 valve. User defines test period as time-dependent or number of start dependent. The test is performed periodically and if a problem is detected, ACH blocks itself. Beside periodic tests, manual test is also available by using M6-UCM SERVICES > U2-UCM TEST menu.

5-I-1) AUTOMATIC (PERIODIC) TEST

At first, test period is defined using P2-AUX. PARAMETERS>B59-UCM CHECK TYPE menu. Here STARTING COUNT or DAILY CONTROL options are available.

When DAILY CONTROL is selected, first test date and time is set by using M6-UCM SERVICES>U3-TEST TIME menu. When selected date and time is reached, controller looks for proper free time slot for test. When lift stays free for 150 seconds then TEST is started. After completing test, next day is assigned for test date and test time remains the same. So in this way everyday approximately at the same time test is performed.

When STARTING COUNT is selected, test period is entered to M6-UCM SERVICES > U4-TEST START menu as number of start. When number of start reaches the multiples of this number, controller looks for proper free time slot for test. When lift stays free for 150 seconds then TEST is started.

Tests are performed in two different ways depending on the parameter A05:FLOOR SELECTOR.

***NOTE 1:** When [B59]=2 (Daily Control) is chosen, optional RTC board must be installed and parameter B44(DATE AND TIME) must be set as 1 (ACTIVATED).*

***NOTE 2:** During TEST procedure, ACH Controller passes to Inspection mode and no calls are accepted.*

5-I-2) AUTOMATIC TEST PROCEDURE DEPENDS ON COUNTER SYSTEM

a) AUTOTEST WITH COUNTER SYSTEM

Controller first moves car in up direction until down releveling is needed. Then down valve is energized but A3 valve is not. SECUR.VALVE TEST message is flashed on the screen for 5 seconds. During 5 seconds if no motion is detected TEST 1+ message is displayed and down valve is shut off. This shows that A3 valve runs properly.

If any motion is detected, then down valve is shut off, ERROR 68: SECU.VALVE FAULT is reported and controller blocks itself permanently.

At next step A3 valve is energized but down valve is not. DOWN VALVE TEST message is flashed on the screen for 5 seconds. During 5 seconds if no motion is detected TEST 2+ message is displayed and A3 valve is shut off. This shows that down valve runs properly.

If any motion is detected, then A3 valve is shut off, ERROR 69: DOWN VALVE FAULT is reported and controller blocks itself permanently. At the end of test, TEST OK message is displayed and controller exits from VALVE TEST menu. Car is moved down to floor level.

b) AUTOTEST WITH ENCODER SYSTEM

In this system, as controller has precise position information no up motion is required at the beginning. Except this point, the similar test procedure is applied. During test, any motion is detected by monitoring encoder pulses. If more than 20-pulse decrease is detected then ERROR 68/69 is reported and system is blocked permanently.

1. MANUEL TEST

Manual test is started using M6-UCM SERVICES > U2-UCM TEST menu. To perform a proper and safe test, following conditions must be confirmed:

1. Be sure that there is nobody inside cabin.
2. Lift must not be used during test.
3. Lift must be in normal mode (not inspection mode) during test.

After starting manual test, all behavior of ACH controller, monitoring and control procedures, error messages, controller responses are the same with automatic test procedure.

***NOTE 1:** During TEST procedure ACH Controller passes to Inspection mode and no calls are accepted.*

***NOTE 2:** Manual test cannot be started when lift is busy.*

c) RESTORING FROM BLOCKED MODE

Enter M6-UCM SERVICES>U1-UCM RESET menu and see CLEAR UCM ERROR message and push ENT button to confirm. This menu is functional only if the conditions causing UCM are fixed.

5-I-3) UCM DETECTION AND CONTROL

a) PREOPENING AND DOOR-OPEN RELEVELLING

Cabin is in door zone and moving in slow or leveling speed. Door is open and Door Bridging circuit bridges safety line. In this case, if any of door zone limit switches (ML1, ML2) is opened, then ACH Controller accepts this as UCM. Door bridge is opened and motion is stopped. Valve and contactor supply is cut immediately. ACH controller passes to out of service mode, reports Error 72:UCM FAULT and blocks itself permanently. Even if ACH board is restarted, it will stay in blocked mode and error report will flash on the screen.

During pre-opening or leveling/releveling if a fault occurs on ACH Door Bridging Circuit and bridging cannot be performed, then lift will be stopped and pass to Inspection mode. ACH controller reports Error 45: BRIDGING ERROR and blocks itself permanently. Even if ACH board is restarted, it will stay in blocked mode and error report will flash on the screen.

Enter M6-UCM SERVICES>U1-UCM RESET menu and see CLEAR UCM ERROR message and push ENT button to confirm. This menu is functional only if the conditions causing UCM are fixed.

***NOTE :** UCM conditions occurring in both cases during pre-opening and releveling with open-door are supposed to be the same.*